



DAC-501

DAC-502

USER MANUAL



weiss.ch

Contents

1	The DAC501/DAC502 Overview	1
2	The three interfaces	2
2.1	The LCD	2
2.2	The IR Remote Control	3
2.3	The Web Interface	3
2.3.1	Basic Introduction	3
2.3.2	Active Output	5
2.3.3	De-Essing	5
2.3.4	The Vinyl Emulator	6
2.3.5	The Equalizer (EQ)	7
2.3.6	The Room Equalizer	8
2.3.7	Headphone EQ	12
2.3.8	Loudness EQ	12
2.3.9	Dynamics Adaption	13
2.3.10	The Crosstalk Cancellation (XTC)	14
2.3.11	Crossfeed Headphone	14
2.3.12	Snapshot Storage	16
2.3.13	Global Presets	17
2.3.14	Firmware Update/ Download	18
2.3.15	M/S Control	18
3	Technical Specification	19
4	Signal Processing Algorithms	24
4.1	The Weiss parametric Equalizer (EQ)	24
4.2	The Weiss Room Equalizer	26
4.3	The Weiss Crosstalk Cancellation (XTC)	26
4.4	The Weiss Vinyl Emulator	27
4.5	Digital level control and Dithering	29
4.6	The Weiss Dynamics Adaption	30
4.7	The Weiss De-Esser	32
4.8	The Weiss Crossfeed Headphone Algorithm	35
4.9	The Weiss Headphone Equalizer	36
4.10	The Schwede Loudness EQ	37
4.11	The Weiss M/S Control	37
5	Contact Information	38

1 The DAC501/DAC502 Overview

**Congratulations on purchasing
the DAC501/DAC502 D/A converter!**



Figure 1: The DAC502

The DAC501/DAC502 are our new state of the art D/A Converters with an unprecedented level of sophistication and versatility.

With the DAC50x we are creating a new paradigm for what used to be a black box device. A typical D/A Converter is a "set and forget" device. Not so with the DAC50x. It adds a number of interesting signal processing features and sports a variety of digital inputs. Balanced, unbalanced and headphone outputs are provided.

Weiss Engineering has a 30 year history in D/A Converter design. In that time span we have learned a thing or two about converter design. The DAC50x is the essence of our experiences.

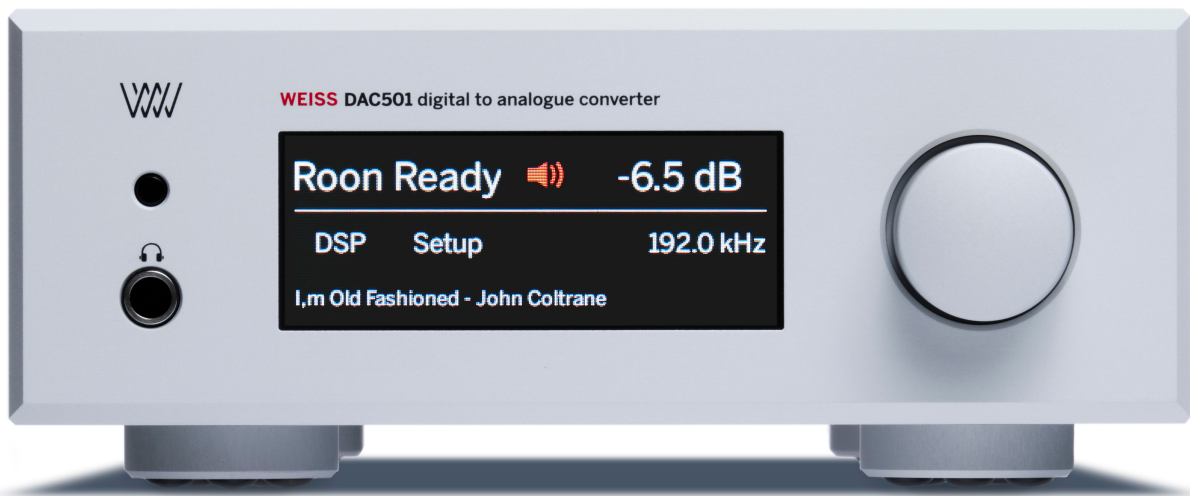

Figure 2: The DAC501

The DAC502 (fig. 1) uses a larger frame but else sports the same features as the DAC501 (fig. 2). Except for an an additional 4 pin headphone socket at the back of the unit. Henceforth the term DAC50x refers to both models.

The basic operation of the DAC50x is outlined in the documentation Quick Start Guide - the first steps with your DAC50x .

For all the powerful features and concepts employed in the DAC50x refer to the detailed overview and White Papers mentioned in the following document. This manual will be updated on a regular basis as new firmware features become available.

2 The three interfaces

We offer you three possibilities to control the DAC50x - so you can adjust the use and interaction of the DAC50x to your own special needs. In the following these three user interfaces are explained in more detail:

- The LCD touch screen and rotary knob on the faceplate
- The IR remote control
- The web interface built into the DAC50x

2.1 The LCD

On the faceplate of the DAC50x you can use the LCD which is a touch screen and the rotary knob to operate with the DAC50x. Tap on the LCD at the:

- **Upper left:** input selection. The *UPnP* selection selects the Ethernet interface as the input.
- **Upper middle:** output select. Only the selected output is active, i.e. *XLR/RCA* or *JACK*. The output which is not selected will be muted. The displayed red icon also shows the output's selected *Output Termination*.
- **Upper right:** volume. If red then the output is muted. By tapping the output is toggled between muted and unmuted. The volume can be changed with the rotary knob. If the value shown is yellow then the absolute polarity of the output is inverted (see below). All parameters can be different between *XLR/RCA* output and *JACK* output.
- **Lower left:** DSP settings. This opens a menu which allows to select one of the DSP algorithms to be changed. (Note, the rotary knob allows to scroll through the menus). The algorithms can be operated via the touch screen, but we recommend to use the web interface (section 2.3) for simpler operation of the DSP features. All parameters can be different between *XLR/RCA* output and *JACK* output. Thus select the appropriate output first (*XLR/RCA* or *JACK*) and then adjust the DSP parameters.
- **Lower middle:** Setup menu. Allows to set the left/right balance, the absolute output polarity, the basic output level in four coarse steps (analog domain) and the LCD back light brightness (the LCD Dim setting is activated after some delay if no parameter is changed any more). (Note, the rotary knob allows to scroll through the menus). The *Balance*, *Polarity* and *Output Level* parameters are stored separately for *XLR/RCA* output and *JACK* output and thus may vary. At the bottom of the setup page a few technical specifications are listed:
 - The hostname which looks similar to this: `dac50x-0010`, meaning that the DAC50x can be accessed via an internet browser as described in the quick start guide.
 - The IP address of the unit in your network.
 - The MAC address, which is a specific address of your unit.
- **Lower right:** Sampling rate of the input signal.
- **Bottom:** Displays the currently played track when in Roon Ready or UPnP input mode (does not necessarily work with WAV or AIFF files).

2.2 The IR Remote Control

Most of the keys on the IR remote control are self-explanatory. Here are some additional remarks:

IR remote control buttons:		
power on/off	select XLR/RCA out	UPnP input
	select JACK out	USB input
volume up		XLR input
volume down		RCA input
mute	polarity	TOS (optical) input
DSP Presets 1	2	3
...		

- The two top/middle keys select the active *Output*. Long press (> 2s) of either keys toggles the active Output's *Termination*.
- The *polarity* key changes the absolute polarity of the output signal. If this is engaged (i.e. signal is inverted), the level figure on the LCD display turns yellow.
- The *mute* key when engaged mutes the output signal completely and the level figure on the LCD turns red.
- The *DSP Presets* keys select one of the Presets stored in the DSP. More information on the DSP Presets is given in the web interface description below.



Figure 3: IR remote control

2.3 The Web Interface

As last but not least possibility to operate with your DAC50x we offer you the Web Interface. This Interface provides you a lot of flexibility and freedom when using the DAC50x. For example you are free to access the web interface via your tablet or your computer.

The web interface will be updated according to new or changed DSP algorithms, which we will supply over time. In order to access this interface your DAC50x must be connected to your local area network where your web-browser is also connected to.

The following sections explain the functionality of the Web Interface.

2.3.1 Basic Introduction

The basic functions and sections of the web interface are marked in fig. 4:

- a : volume control, muting
- b : L/R balance
- c : input selection
- d : coarse output level and polarity tied to the output type
- e : DSP plugin selection
- f : Snapshot and Preset storage
- g : Firmware updating

DAC501 web interface

44.1 kHz
Green - Four Tet

⏮
⏪
⏩
⏭





Volume (a)





Balance (b)



Center

Input Source (c)

XLR
RCA
TOS
USB
UPnP
Room Ready

Active Output

XLR/RCA
JACK

Output Level (d)

0 dB
-10 dB
-20 dB
-30 dB

Output Polarity

Normal
Inverted

DSP Plugins (e)

DeEsser
Vinyl
EQ
Headphone EQ
Loudness EQ
Dynamics
Crossfeed HP



Vinyl Emulation

Enable
Bypass

Saturation



0.0 dB

Bypass (Factory Preset) ▼

Snapshot -

▶ Global Presets
(f)

Firmware (g)

[Release Notes](#)

	Version	Revision	Date	Status
Current	v2.5.1	r2999	2022-02-08 13:13:40+0100	Check for Update Abort
New				<div style="width: 100px; height: 10px; background-color: #6c757d; border: 1px solid #6c757d; display: flex; justify-content: space-between; align-items: center;"> 0 % </div>

Device

Model	DAC501	Rename
Serial #	0001	
Hostname	DAC501-0001	
IP address	192.168.179.13	
MAC address	20:cd:39:f7:ba:9d	

2.3.2 Active Output

Select either *XLR/RCA* or *JACK* with the *Active Output* switch (d). Furthermore the *Output Termination* switch (right hand on DSP plugin bar (e)) allows you to specify for each of these two outputs whether it is associated with a speaker or headphone setup.

Most DSP plugins are available on either *Output Termination* setting. Certain plugins are exclusive to the respective termination setting and are shown/disabled on the DSP plugin bar depending on the *Output Termination* selection.

The *Crossfeed HP* and *Headphone EQ* algorithms are exclusively available for headphone termination settings. *Room EQ* and *XTC* are only provided for speaker termination settings.

2.3.3 De-Essing

The De-Esser plugin reduces critical sounds of sharpness that can occur in the high frequency content of music. So this plugin can be beneficial if your favourite recording contains some unpleasant harsh sounds. But sharpness can also arise during mastering or as a results of inapt constellations in the playback room.

The De-Esser plugin offers you two setting possibilities - the *Amount* and the *Mode* of the De-Esser. The

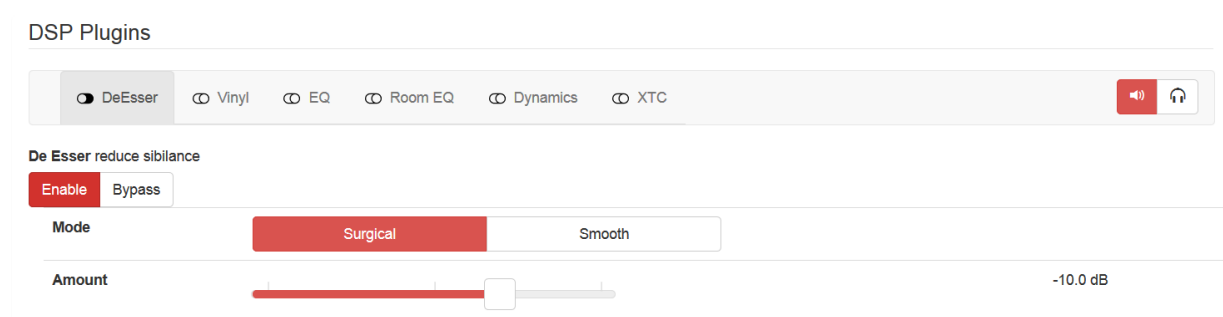

Figure 5: De-Esser plugin

two modes behave different when critical sharpness is detected and can be selected via tapping on the desired mode. The red highlighting displays which mode is active. For selectively getting rid of unpleasant sharpness the mode *Surgical* is preferential. If an overall mellow sound of the high frequency content is desired the mode *Smooth* is recommendable. The disparity of the two modes and how to use them is described in detail in section 4.7. By changing the *Amount* slider you can change the impact of De-Esser effect. When the slider is on position 0dB the influence of the De-Esser is maximal.

2.3.4 The Vinyl Emulator

By tapping or touching on the desired plugin at the light gray tab its special functionality and user parameters will be displayed below the gray tab.

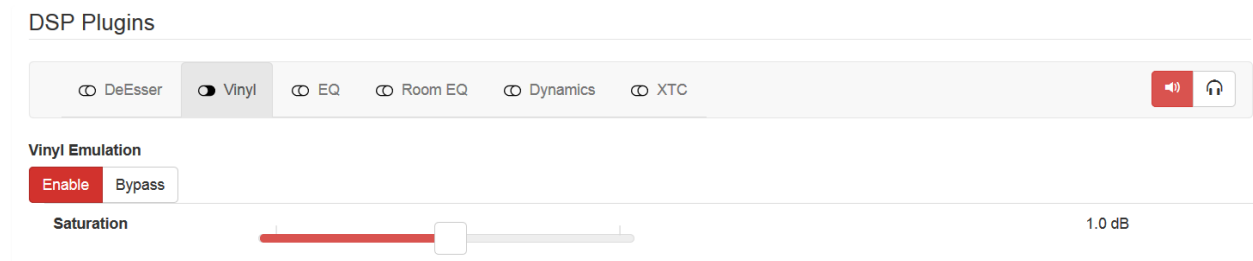

Figure 6: Vinyl plugin

For marking which plugin is displayed the selected plugin will be highlighted in a darker gray. In this screen shot the Vinyl plugin is selected. To switch a plugin on/off just tap on the enable/bypass tab. The selection is highlighted in red.

By moving the slider you can adjust the user parameter Saturation. The Saturation parameter adjusts the amount of the vinyl emulation effect. It has to be adjusted depending on the loudness of the recording and depending on the amount of effect which is expected by the listener.

Note that for too high Saturation settings the audio quality can get poor. Start with e.g. the 0dB setting. The grade of the Saturation is displayed at the right in dB.

2.3.5 The Equalizer (EQ)

In the following screen shot the EQ plugin is selected. This plugin offers you 3 bands of equalization. All settings can be defined by you.

A frequency response magnitude plot over all bands gives an informative overview of your EQ settings.

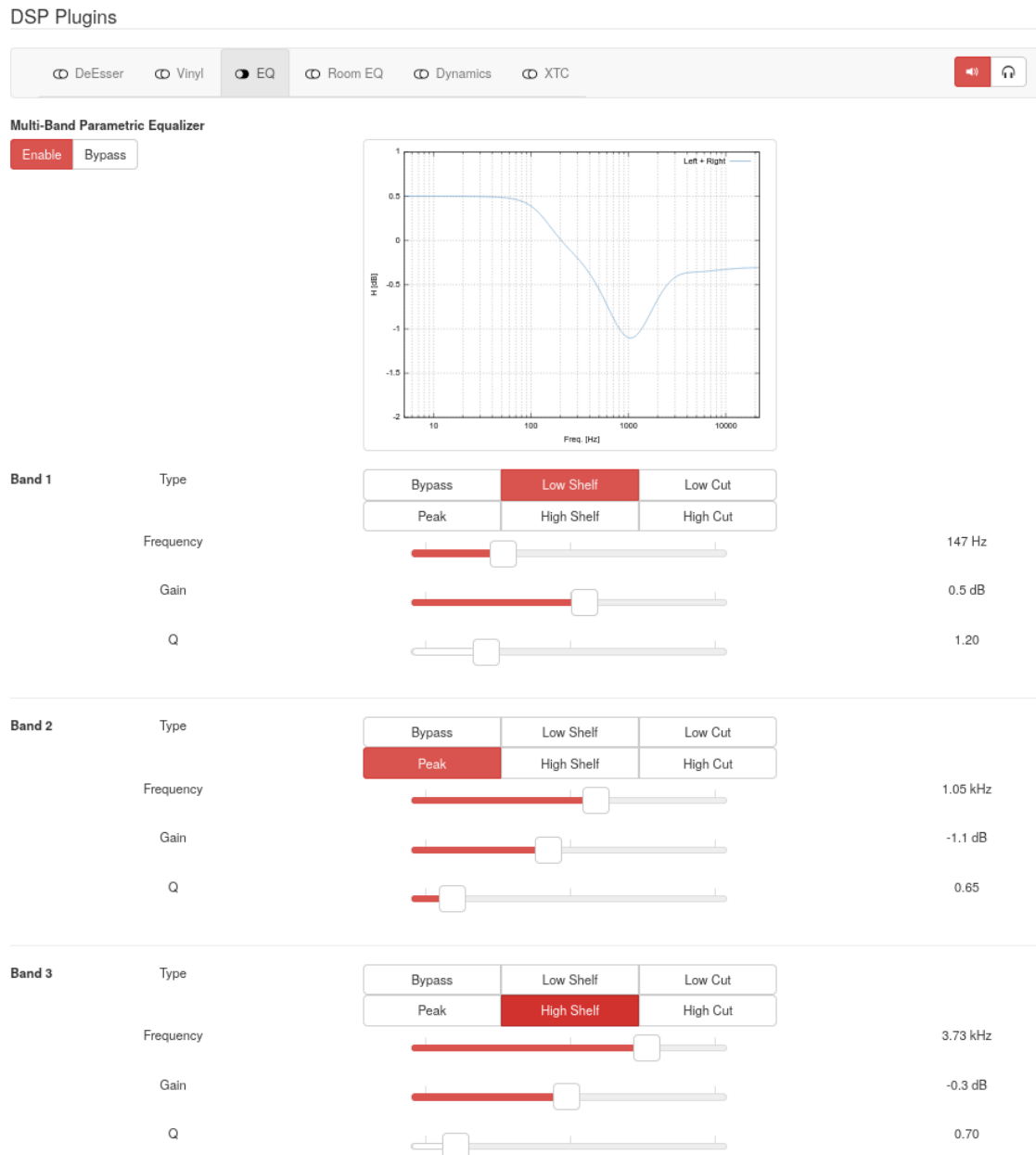

Figure 7: Equalizer plugin

A little example should give you an idea of the functionality and the manifold opportunities the EQ offers:

- The 1st band is set to low shelving with a boost of 0.5dB at 147 Hz, i.e. frequencies below 147 Hz get boosted by 0.5dB.
- The 2nd band is a bell shaped peaking filter, attenuating 1.1dB at 1.05 kHz. The Q value is the width of the bell shape. The smaller the Q the wider the bell.
- The 3rd band is a high shelving filter, attenuating frequencies above 3.73 kHz by 0.3dB

2.3.6 The Room Equalizer

DSP Plugins

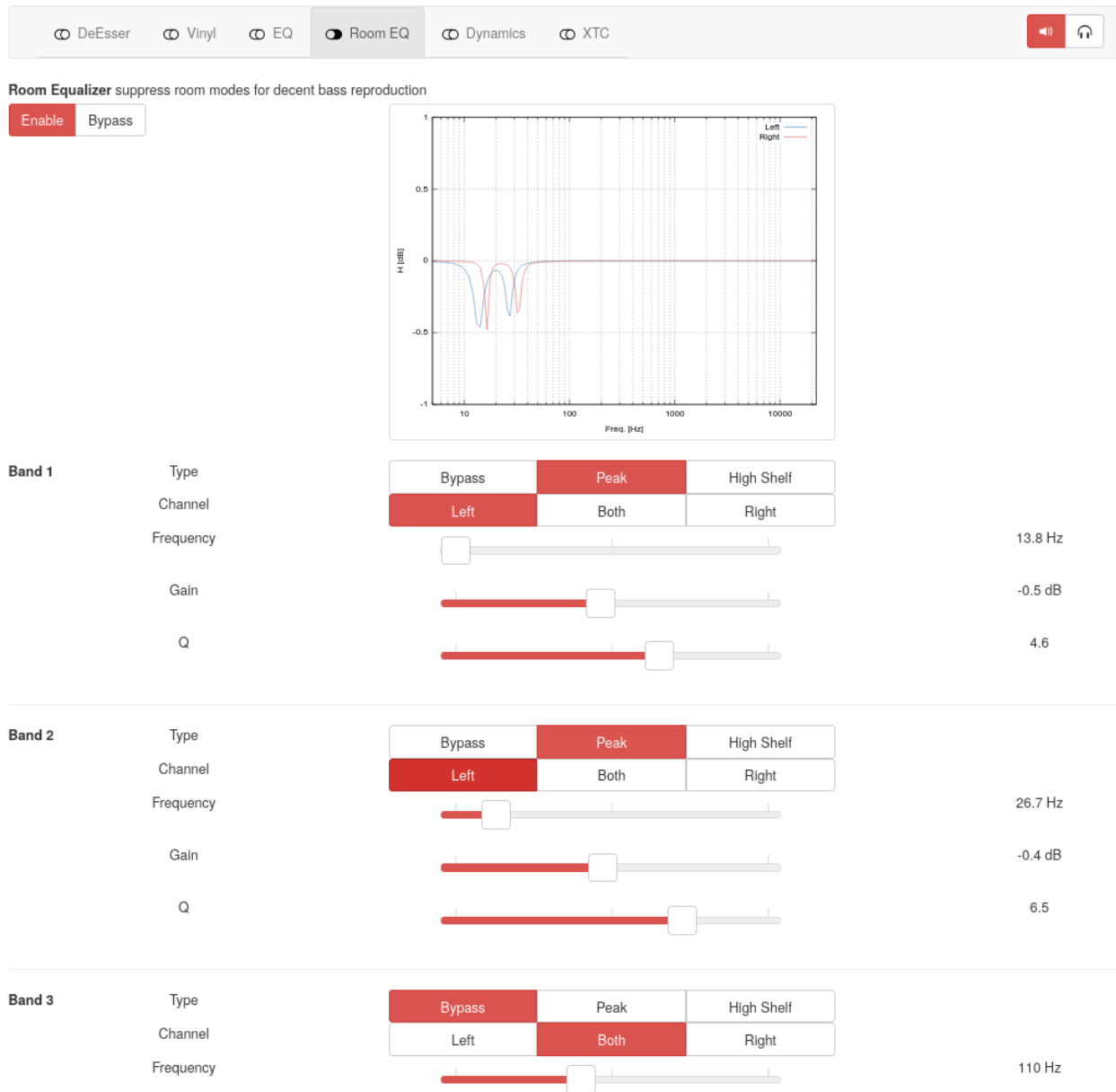

Figure 8: Room EQ plugin

5 bands of room equalization are available. Only peaking mode makes sense such that certain (low) frequencies can be attenuated with a sensible bell width set with the Q parameter. A frequency response magnitude plot over all bands gives an informative overview of your Room EQ settings.

Consider the following instructions on how to set up the Room EQ with a simple procedure, without using any measurement.

In an alternative setup scenario we will use the room measurement software of the Illusonic company. (In development.)

The simple setup procedure for the Room EQ uses a sine-wave sweep audio file to be played back via your speaker setup. During playback you will write down the time(s) where the loudness of the sine wave reaches a maximum, i.e. where the so called room modes show up. Those time figures then allow to determine the

frequencies of the sine wave and thus allow you to set the bands of the Room EQ in order to attenuate those frequencies.

During the frequency sweep you probably will also notice some dips in the loudness. This is normal, as the sine waves coming from your speakers add and subtract with the sine waves reflected from the room walls. The added waves are what we try to suppress with the Room EQ.

The subtracted ones (loudness dips) cannot be corrected with a Room EQ or only to a very limited amount. Do not try to lift those dips to full level, it won't work. The problem with lifting the levels is that the Room EQ (or your speakers) can easily get into overload and then generate nasty clipping noises.

The procedure is as follows:

1. Get one of these files from our website, one is in FLAC format the other in WAV:
<https://www.weiss.ch/downloads/dac501/room-eq1.flac>
<https://www.weiss.ch/downloads/dac501/room-eq1.wav>
2. Make sure to sit at your normal listening position (this is essential).
3. Play the file via your speakers at normal loudness (does not have to be loud). Note that the Room EQ can be set individually for the left and the right speaker. Or can be set the same for both speakers. If you decide to set them individually, e.g. because your speaker setup / room geometries are not completely symmetrical, then do the following steps individually for left and right channels. Each band of the Room EQ can have different settings in left and right. Make sure that only one speaker is playing when setting left and right individually. You can select the proper speaker via the *Balance* fader.
4. Write down the time(s) into the playback where you hear a maximum volume of the sine wave. If necessary repeat the test to find all those maxima.
5. If your listening room is not too complex in terms of wall geometries you may visit this website and calculate the potential room mode frequencies by entering the dimensions of your listening room: <https://amcoustics.com/tools/amroc> (This can help with determining the proper frequencies).
6. Get this PDF file with a table to translate the times you have written down to the frequency of the sine wave: <https://www.weiss.ch/downloads/dac501/sine-sweep.pdf> - or use the table on the next page.
7. Write down the frequencies according to the table.
8. Now activate the Room EQ in your DAC501/DAC502 unit. Enable first the overall Room EQ and then enable one frequency band after the other as required (i.e. tap on the *Peak* pad to enable a band).
9. Select the first frequency you like to process, i.e. set the *Frequency* fader to the proper frequency according to your list.
10. Move the *Q* fader to a value around 14 to start with. The *Q* is the Quality parameter which is the bandwidth of the notch filter we apply to suppress the frequency. The higher the *Q* parameter the narrower the notch. A high *Q* makes sure that not too many frequencies around the annoying frequency are affected by the notch. On the other hand a high *Q* may cause that frequencies close to the one we have selected still get through and excite the room mode.
11. Move the *Gain* fader to the left to e.g. -15dB to start with.
12. Now you may play the sine wave sweep again and check the frequency range around the frequency you have selected to suppress. Check whether the listening volume stays about constant now, i.e. whether the room mode is suppressed properly. If necessary adjust the *Gain* parameter. If you can't get a proper result by adjusting the *Gain* parameter (i.e. you always get too much loudness at the room mode frequency) then adjust the *Q* value to a lower value and then try again with the *Gain* parameter.
13. Now select another frequency you may have on your list and proceed from 8) above again. Usually there are only a very few frequencies which need treatment, so the 5 bands of the Room EQ should be fine.

Once you have properly set the Room EQ you will notice a much clearer reproduction, without boomed bass. Note, you may have gotten used to the acoustics of your playback setup and then when correcting it with the Room EQ it may sound strange at first. But keep it and listen to it, you will get used to it again and enjoy listening to a better reproduction chain.

Time in seconds	Frequency in Hz	Time in seconds	Frequency in Hz
4	200	77	65
4	199	78	64
5	197	79	63
6	194	80	62
7	191	81	61
8	188	82	60
9	185	83	59
10	182	84	58
11	179	85	57
12	177	86	56
13	174	87	56
14	171	88	55
15	169	89	54
16	166	90	53
17	163	91	52
18	161	92	51
19	159	93	51
20	156	94	50
21	154	95	49
22	152	96	48
23	149	97	48
24	147	98	47
25	144	99	46
26	142	100	45
27	140	101	45
28	138	102	44
29	136	103	43
30	134	104	43
31	132	105	42
32	130	106	41
33	128	107	41
34	126	108	40
35	124	109	40
36	122	110	39
37	120	111	38
38	118	112	38
39	117	113	37
40	115	114	37
41	113	115	36
42	111	116	36
43	109	117	35
44	108	118	34
45	106	119	34
46	105	120	33
47	103	121	33
48	101	122	32
49	100	123	32
50	98	124	31
51	97	125	31
52	95	126	30
53	94	127	30
54	92	128	30
55	91	129	29
56	90	130	29
57	88	131	28
58	87	132	28
59	86	133	27
60	84	134	27
61	83	135	26
62	82	136	26
63	80	137	26
64	79	138	25
65	78	139	25
66	77	140	24
67	76	141	24
68	74	142	24
69	73	143	23
70	72	144	23
71	71	145	23
72	70	146	22
73	69	147	22
74	68	148	22
75	67	149	21
76	66	150	21
		151	21
		152	20
		153	20

2.3.7 Headphone EQ

DSP Plugins

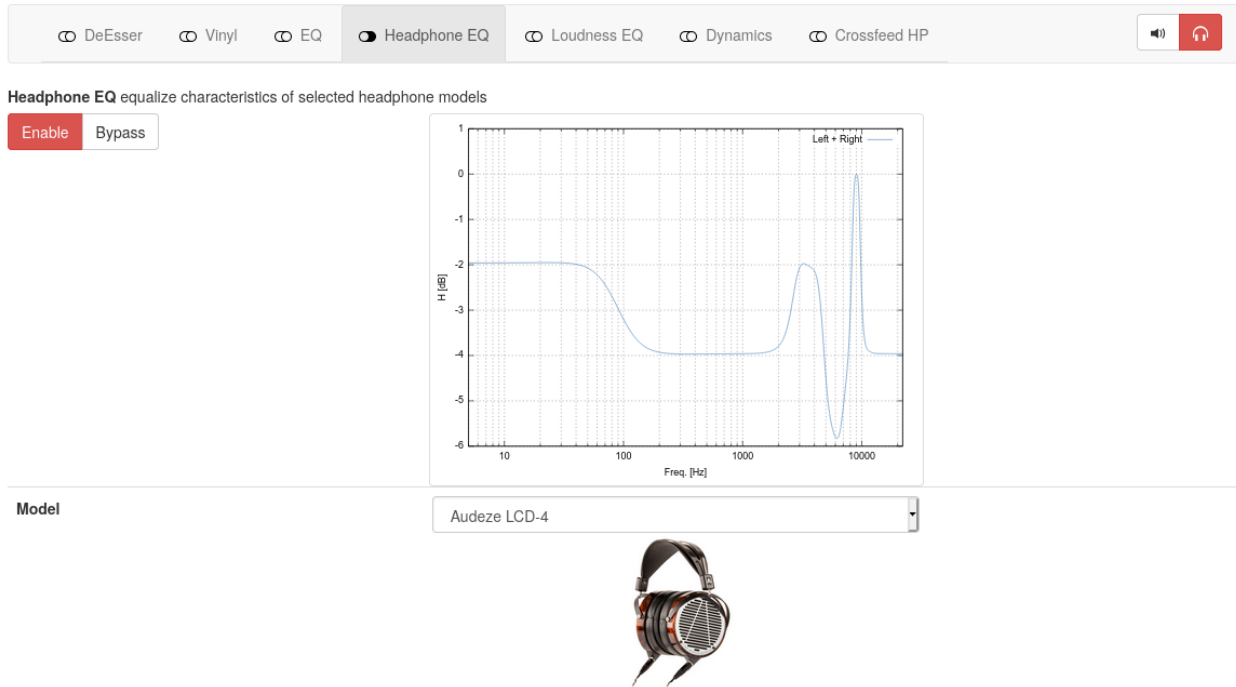

Figure 9: Headphone EQ plugin

Fig. 9 shows the headphone EQ plugin. Select your headphones *Model* using the drop-down menu. Based on your selection an associated photo of the current headphone model is displayed, click on it to show the manufacturer's product website.

In addition the frequency response of the corresponding headphone EQ will be plotted. The EQ setting is designed by the manufacturer and tailored to optimize the sound of the headphone. These specified EQ designs can not be altered by the user.

2.3.8 Loudness EQ

The loudness EQ visualized in figure 10 is based on the Equalizer patent of Bernhard Schwede². The idea behind this equalization is based on psychoacoustic grounds.

Mainly the psychoacoustic quantity *loudness* is eponymous and essential for the EQ design by Schwede. In acoustics this loudness describes the subjective perception of sound pressure¹. Schwedes EQ design then considers this subjective perception to create a more pleasant playback regarding the sound intensity. The specific design of Schwedes patent is implemented in the presented plugin.

Summing up this EQ offers you the possibility to influence playback volume in such a way that the resulting loudness impression becomes more authentic throughout the audible frequency spectrum.

Choose your desired loudness *Level* via the drop-down menu. These ten different level settings in dB are illustrated with comparisons benefiting an intuitive use of this plugin. Starting at the lowest level at 60 dB you can increase the loudness up to 105 dB.

²Patent specification: EP 3 123 471 B: Schwede, Bernhard "Equalizer, audio system with such an equalizer and method for equalizing a sound mix". <https://data.epo.org/publication-server/pdf-document/EP15712869NW1.pdf?PN=EP3123471%20EP%203123471&iDocId=5586961&iepatch=.pdf>

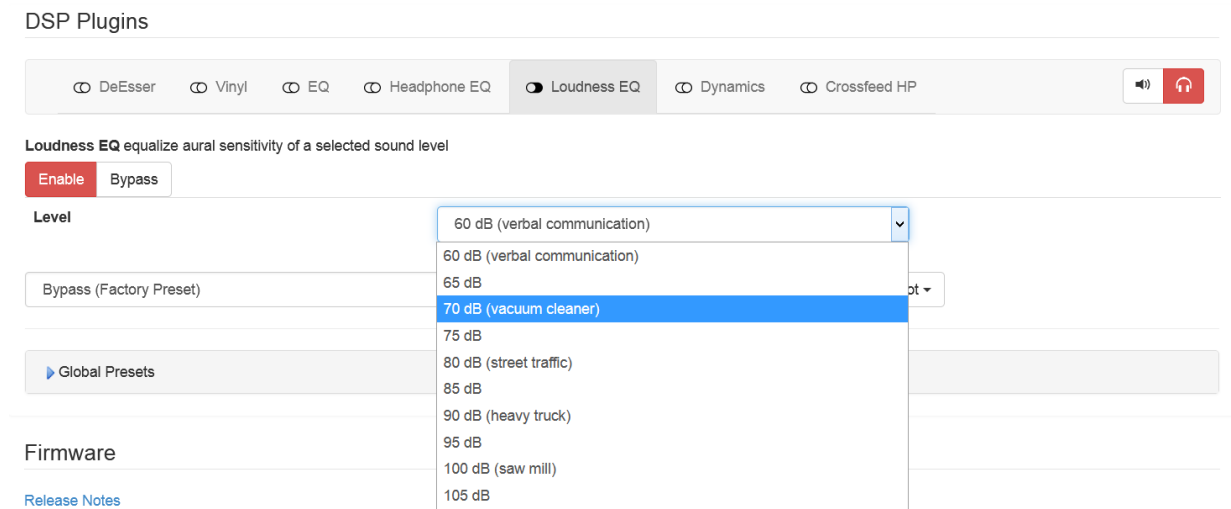

Figure 10: Loudness EQ plugin

2.3.9 Dynamics Adaption

In the following screen shot the Dynamics Adaption or shortly Dynamics plugin is selected and enabled.

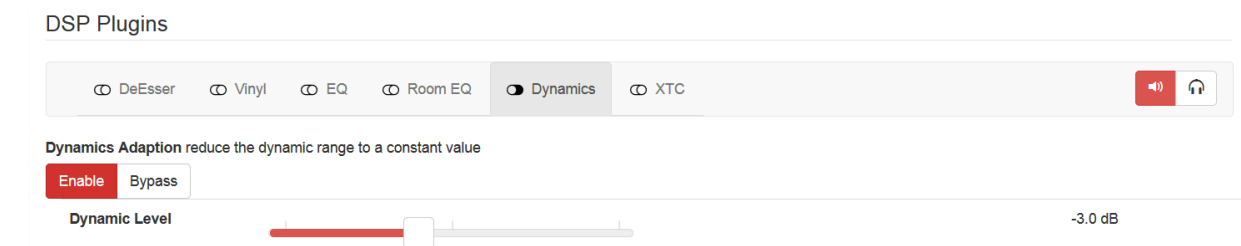

Figure 11: Dynamics Adaption plugin

This plugin reduces the dynamic range of the played audio to a constant value. This is useful when listening to a desired play list with songs that have quite a different loudness - for example while having a dinner with friends. With this plugin your play list will be played with overall the same loudness impression.

To adjust how strong this dynamic range reduction should affect the playback you can set the Dynamic Level. If you want to have less dynamics left in the output choose a low Dynamic Level. If you want to have still a lot of dynamics left but avoid loud peaks increase the Dynamic Level again. We recommend you to start with a Dynamic Level at 0dB.

Note, the Dynamics Adaption algorithm apparently depends on the level fed into the algorithm. We recommend to feed the DAC50x with the maximally possible level. I.e. have any digital level control which may be sitting in front of the DAC50x (like e.g. a network player output) set to the maximal level.

2.3.10 The Crosstalk Cancellation (XTC)

The XTC processing is a special kind of filtering which allows to reduce the crosstalk between the left speaker and the right ear and between the right speaker and the left ear.

Thus the playback resembles a playback via headphones (where that crosstalk is close to zero), but speakers are used and thus the problems with headphone playback (e.g. in-head localization) are avoided.

the XTC plugin is selected →

enable is highlighted in red →

Distance between speaker centers → in meters

Distance listener → to baseline between speakers

Listener's head width →

Mid frequency attenuation →

High frequency attenuation →

DSP Plugins

DeEsser Vinyl EQ Room EQ Dynamics **XTC**

Crosstalk Cancelling

Enable Bypass

Distance Speakers 0.50 m

Distance Listener 2.00 m

Head Width 15 cm

Attenuation BP -6.0 dB

Attenuation HP -12.0 dB

Figure 12: XTC plugin

With the XTC playback the listeners gets a live-like listening experience. The sound stage extends beyond the speakers and even becomes 3-dimensional with certain recordings. The best suited recordings are those made with a dummy head (binaural recordings) and live recordings also are often suited very well. The dummy head is a plastic model of a human head with microphones in its ears. This head is placed in the concert hall in order to record the performance in a 2-channel manner.

XTC works best if the speakers are fairly close to each other compared to the listener distance. Set the geometry of your setup with the Distance Speakers and Distance Listener faders. If the geometry is not very well suited for the XTC playback, the background of the two fader sections turns yellow.

The XTC may still work but may be compromised. Note, the listener distance is the distance between listener and the baseline between the speakers.

Also set your head width with the appropriate fader. This value is not that critical. 15cm is a typical head width.

With the Attenuation parameters set the XTC for best performance. Start the Attenuation BP fader at the left and move it to the right for an optimal setting. Around -5dB is a typical value for a good performance.

The *Attenuation HP* you may set to the same value as the *Attenuation BP* or experiment with its setting. The *Attenuation HP* controls the XTC of the high frequency band, so changes may be more difficult to notice. The *Attenuation BP* controls the mid frequency band.

The low frequencies are not crosstalk cancelled at all. After setting all parameters you may switch back and forth between XTC on and off to check the effect. You may notice a loss in the low frequency band when switching on the XTC. This can be compensated with the EQ plugin. E.g. boost the low frequencies at around 150Hz with a peaking filter at Q around 1.4 and a boost of a few dBs.

2.3.11 Crossfeed Headphone

The Crossfeed Headphone plugin is designed to enhance the playback via headphones. Its usage is especially recommended when listening to audio with high channel separation. Furthermore it creates a more

roomy sound scape, similar to loudspeaker reproduction in a room.

The Crossfeed Headphone plugin allows adjusting the *Amount* level between 0 and 100 in order to achieve your preferential setting. A higher *Amount* results in stronger impact of the plugin's effect on the played back audio.

See section 4.8 for further details about this plugin.

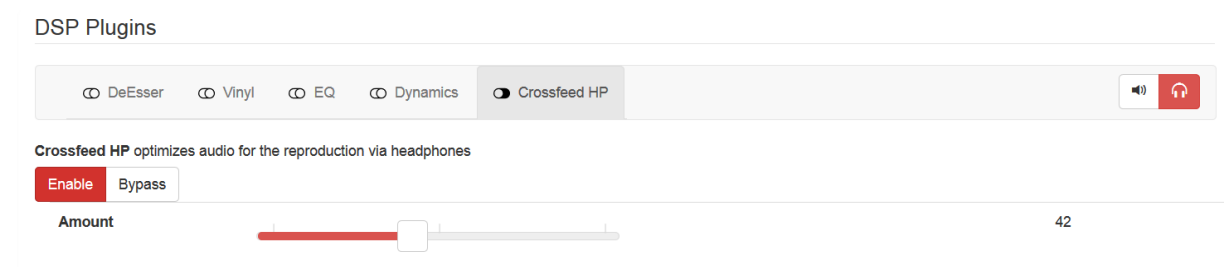

Figure 13: Crossfeed HP plugin

2.3.12 Snapshot Storage

Snapshots allow you to save and recall your favorite DSP plugin settings. Each plugin maintains its own set of snapshots. Moreover snapshots can be used to assemble *Global Presets* (section 2.3.13).

Select your intended DSP plugin and adjust its parameters as desired. Whether a plugin is enabled or bypassed is also part of its setting and will be stored in the snapshot.

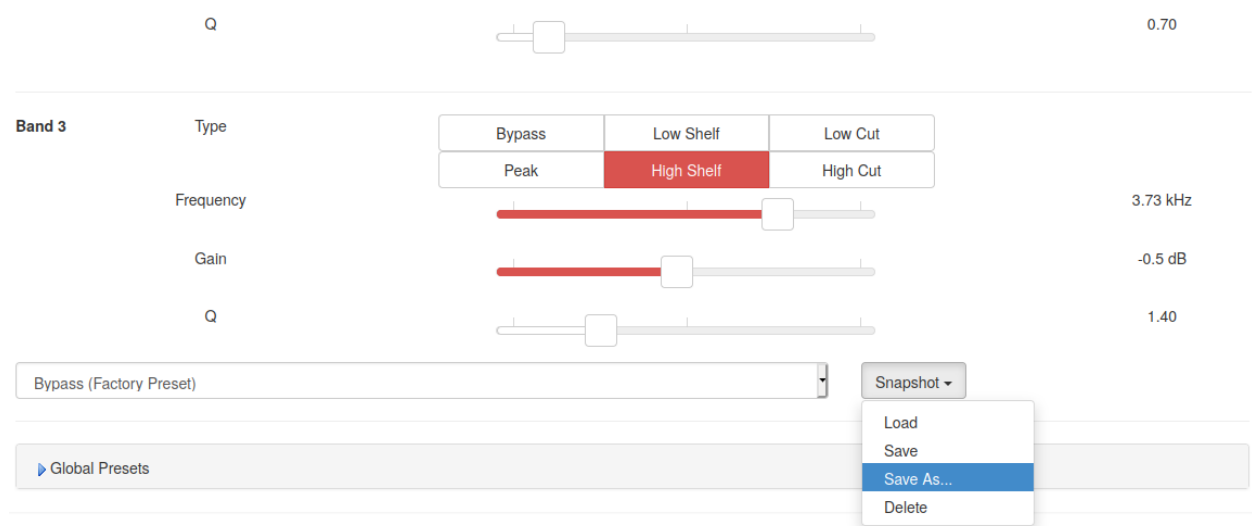

Figure 14: Snapshots maintenance

In order to recall a stored snapshot select it by name from the list and tap on *Snapshot* → *Load*.

Store a plugin's current setting by tapping on *Snapshot* → *Save As...* to generate a new snapshot (with name and optional description, see fig. 15).

Or use *Snapshot* → *Save* to overwrite the currently selected snapshot.

Note: Snapshots pre-marked with *Factory Preset* cannot be overwritten or deleted but may serve as convenient starting points for your own snapshots.

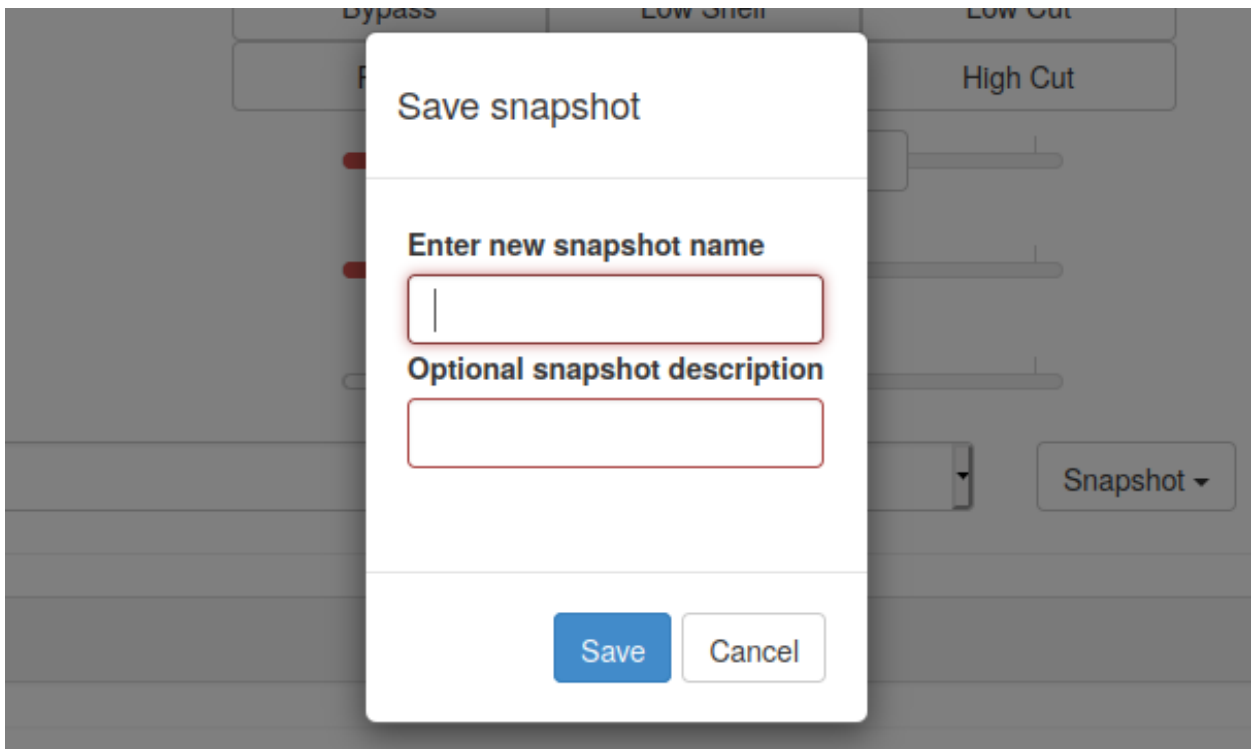

Figure 15: Saving a new snapshot

2.3.13 Global Presets

The 12 Global Presets are a useful facility to compose and quickly recall your favourite settings. Each Preset can be recalled from the Global Preset composer matrix or via the 12 DSP Preset keys on the IR remote control.

A Preset is composed of Snapshots from the individual DSP plugins (section 2.3.12). Preset 1 in fig. 16 consists of the *Smiley1* EQ Snapshot while the other DSP algorithms are bypassed.

The plugin sequence within the composer matrix reflects the actual sequence of the DSP processing. Preset snapshot dropdown lists of plugins which are currently not applicable (due to current *Output Termination* setting, see section 2.3.2) are not shown.

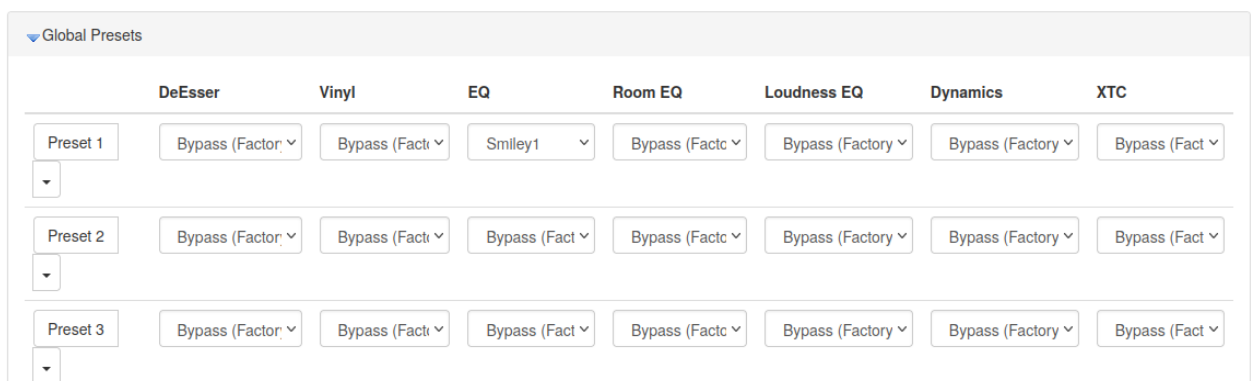

Figure 16: Global Preset composer matrix

With additional DSP plugins in future firmware upgrades the preset composer matrix will obviously grow. Furthermore we will supply multiple built-in factory preset snapshots as suggestions for sensible presets.

Note: Each *Output* and each *Output Termination* has its own separate set of Presets. So there is a total of

48 Presets, 12 each for *XLR/RCA* and *JACK* and their *Output Termination (Speakers or Headphones)*. If the *Output* and/or *Output Termination* is changed the Preset bank is automatically changed as well.

2.3.14 Firmware Update/ Download

Firmware

[Release Notes](#)

	Version	Revision	Date	Status
Current	v1.7.0	r1779	2018-11-06 17:31:32+0100	<input type="button" value="Check for Update"/> <input type="button" value="Abort"/>
New				<input type="text" value="0 %"/>

Figure 17: Firmware update

At the bottom of the web interface there is the *Check for Update* pad. Tapping on that pad starts the DAC50x to connect to our Server to see whether there is any new device firmware available. (The DAC50x has to be connected via Ethernet to your internet router.)

If new firmware is available the pad allows to download the firmware (allow for some time due to internet speed) and after download the firmware can be activated (also allow some time for this).

Once this has been done the DAC50x needs to be rebooted in order to get the new firmware running.

For detailed information about the new and previous firmware releases tap on the *Release Notes* link.

2.3.15 M/S Control

→ to be announced

3 Technical Specification

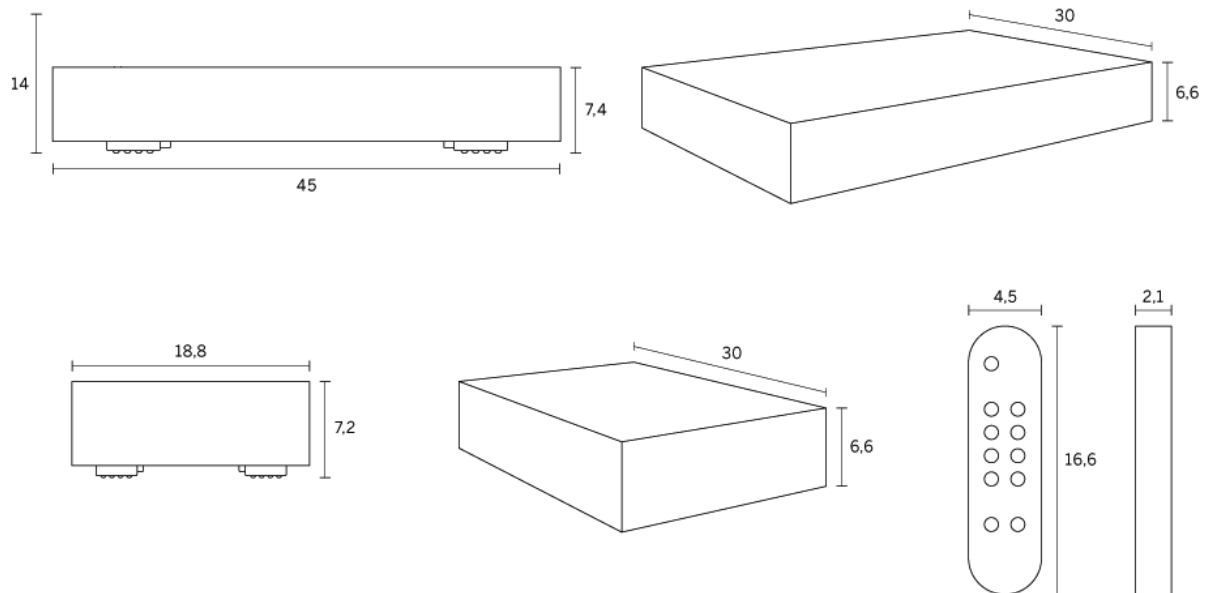

Figure 18: Engineering drawings of the DAC501, DAC502 and the IR remote control

Power:

- Mains voltage: *100...120 V or 200...240 V*, automatic voltage selection
- Fuse rating: *500 mA* slow blow
- Power consumption: *25 VA max.*
- Power consumption in standby: *2.2 VA max.*

Size DAC501

- Depth: *30 cm*
- Width: *18.8 cm*
- Height: *6.6 cm*
- Height with feet: *7.2 cm*

Size DAC502

- Depth: *30 cm*
- Width: *45 cm*
- Height: *6.6 cm*
- Height with feet: *7.4 cm*

Size Remote:

- Depth: *2.1 cm*
- Width: *4.5 cm*
- Height: *16.6 cm*

Available Colours: Silver, Black

Digital Inputs

- (1) XLR connector
- (1) RCA connector
- (1) TOSLINK connector (optical)
- (1) USB type B connector
- (1) RJ45 Ethernet connector

→ All inputs accept professional or consumer standard, i.e. accept AES/EBU or S/PDIF signals.

Sampling frequencies

- AES/EBU and S/PDIF inputs:
 - 44.1 kHz, 48 kHz, 88.2 kHz, 96 kHz, 176.4 kHz, 192 kHz
- USB and RJ45 Ethernet inputs:
 - 44.1 kHz, 48 kHz, 88.2 kHz, 96 kHz, 176.4 kHz, 192 kHz, 352.8 kHz, 384 kHz, DSD64, DSD128
- Toslink input:
 - 44.1 kHz, 48 kHz, 88.2 kHz, 96 kHz

Input word-length: max. 24 / 32 Bits

Digital Outputs: None

Analog Outputs

- (2) XLR connectors (hot on pin 2), short circuit proof output circuitry, DC coupled, low output impedance
- (2) RCA connectors, short circuit proof output circuitry, DC coupled, low output impedance
- (1) 6.3mm Jack socket for headphones, DC coupled, low output impedance
- DAC502 only: (1) 4 pin XLR socket for headphones, DC coupled, low output impedance

The output level is selectable via the LCD menu or the web interface; four settings are provided as shown below:

XLR Output

- 0dB setting: $6.8 V_{\text{rms}} +18.9 \text{ dBu}$
- -10dB setting: $2.2 V_{\text{rms}} +8.9 \text{ dBu}$
- -20dB setting: $0.68 V_{\text{rms}} -1.1 \text{ dBu}$
- -30dB setting: $0.22 V_{\text{rms}} -11.1 \text{ dBu}$

→ As input a 0 dBFS sine wave signal was used

→ These levels are achieved with a 0.0 dB setting for the level control on the LCD screen.

RCA Output:

- 0dB setting: $3.4 V_{\text{rms}}$ +12.9 dBu
- -10dB setting: $1.1 V_{\text{rms}}$ +2.9 dBu
- -20dB setting: $0.34 V_{\text{rms}}$ -7.1 dBu
- -30dB setting: $0.11 V_{\text{rms}}$ -17.1 dBu

→ As input a 0 dBFS sine wave signal was used

→ These levels are achieved with a 0.0 dB setting for the level control on the LCD screen.

Headphone Output:

- (1) stereo 1/4-inch jack connector, DC coupled. The output level is selectable via the LCD menu; four level settings are provided as shown below:
 - 0 dB setting: $6.8 V_{\text{rms}}$ +18.9 dBu
 - -10 dB setting: $2.2 V_{\text{rms}}$ +8.9 dBu
 - -20 dB setting: $0.68 V_{\text{rms}}$ -1.1 dBu
 - -30 dB setting: $0.22 V_{\text{rms}}$ -11.1 dBu

→ As input a 0 dBFS sine wave signal was used

→ These levels are achieved with a 0.0 dB setting for the level control on the LCD screen.

Suggested headphone impedances:

- 0 dB setting: 200Ω or higher
- -10 dB setting: 30Ω or higher
- -20 dB setting: 10Ω or higher
- -30 dB setting: 4Ω or higher

→ The same parameters apply to the 4 pin headphone output of the DAC502 as well.

Synchronization

Via the input signal in case of the AES/EBU and S/PDIF inputs. Via the internal oscillator in the case of USB and Ethernet inputs.

D/A Converter chip

Over-sampling multi-bit sigma-delta converter - Two converters per audio channel.

Measurements XLR/RCA Output

The measurements below have been taken at the following conditions (unless noted otherwise):
 1 kHz measurement frequency, maximum selectable output level, 192 kHz sampling frequency (Fs),
 22 kHz measurement bandwidth, unweighted, 0 dB equals the output level at 0 dBFS input.

Frequency Response:
<i>F_s</i> = 44.1 kHz, 0 Hz...20 kHz: within ± 0.25 dB
<i>F_s</i> = 88.2 kHz, 0 Hz...20 kHz: within ± 0.25 dB
<i>F_s</i> = 88.2 kHz, 0 Hz...40 kHz: within ± 0.8 dB
<i>F_s</i> = 176.4 kHz, 0 Hz...20 kHz: within ± 0.25 dB
<i>F_s</i> = 176.4 kHz, 0 Hz...40 kHz: within ± 0.8 dB
<i>F_s</i> = 176.4 kHz, 0 Hz...80 kHz: within ± 2.5 dB
Total Harmonic Distortion plus Noise (THD+N):
-111 dBr at -3 dBFS input level
-125 dBr at -40 dBFS input level
-125 dBr at -70 dBFS input level
Linearity:
At 0 dBFS to -120 dBFS input level: less than ±0.2 dB deviation from ideal
Spurious components (including harmonics):
At 0 dBFS input level, maximum output level, 1 kHz, all components at less than -110 dB
At 0 dBFS input level, maximum output level, 4 kHz, all components at less than -110 dB
Crosstalk:
Better than 110 dB, 20 Hz...20 kHz
Inter channel Phase Response:
±0.3° 20 Hz...20 kHz
±0.6° 20 Hz...40 kHz

Measurements Jack Output

The measurements below have been taken at the following conditions (unless noted otherwise):
 1 kHz measurement frequency, maximum selectable output level, 192 kHz sampling frequency (Fs),
 22 kHz measurement bandwidth, unweighted, 0 dB equals the output level at 0 dBFS input.

Frequency Response:
<i>F_s = 44.1 kHz, 0 Hz...20 kHz: within ± 0.25 dB</i>
<i>F_s = 88.2 kHz, 0 Hz...20 kHz: within ± 0.25 dB</i>
<i>F_s = 88.2 kHz, 0 Hz...40 kHz: within ± 0.8 dB</i>
<i>F_s = 176.4 kHz, 0 Hz...20 kHz: within ± 0.25 dB</i>
<i>F_s = 176.4 kHz, 0 Hz...40 kHz: within ± 0.8 dB</i>
<i>F_s = 176.4 kHz, 0 Hz...80 kHz: within ± 2.5 dB</i>
Total Harmonic Distortion plus Noise (THD+N):
-112 dBr (0.00025 %) at -3 dBFS input level
-121 dBr (0.000089 %) at -40 dBFS input level
-121 dBr (0.000089 %) at -70 dBFS input level
Linearity:
At 0 dBFS to -120 dBFS input level: less than ±0.4 dB deviation from ideal
Spurious Components (including Harmonics)::
At 0 dBFS input level, maximum output level, 100kΩ load, 1 kHz, all components at less than -110 dB
At 0 dBFS input level, maximum output level, 600Ω load, 1 kHz, all components at less than -110 dB
At 0 dBFS input level, maximum output level, 300Ω load, 1 kHz, all components at less than -110 dB
At 0 dBFS input level, maximum output level, 100kΩ load, 4 kHz, all components at less than -110 dB
At 0 dBFS input level, maximum output level, 600Ω load, 4 kHz, all components at less than -110 dB
At 0 dBFS input level, maximum output level, 300Ω load, 4 kHz, all components at less than -110 dB
Crosstalk:
Better than 105 dB, 20 Hz...20 kHz
Interchannel Phase Response:
±0.2° 20 Hz...20 kHz
±0.5° 20 Hz...80 kHz

4 Signal Processing Algorithms

4.1 The Weiss parametric Equalizer (EQ)

The parametric equalizer is one of the most used tools in the professional audio production studio. It allows to shape the tonal character of a recording or of single instrument tracks with great precision. This is due to the fact that all the parameters of the EQ can be user set. I.e. the frequency where the EQ acts, the width of the bell shaped EQ curve and the amount of boost or cut all can be set independently.

The EQ in the DAC50x has three independent bands. Each of them can be set to a mode, namely low cut/high cut (to get rid of disturbing low or high frequencies), low shelf/high shelf (to boost or cut low or high frequencies) or peaking (to boost any frequency with a bell shaped curve with a variable width).

Here are a few examples of frequency responses achievable with the parametric EQ:

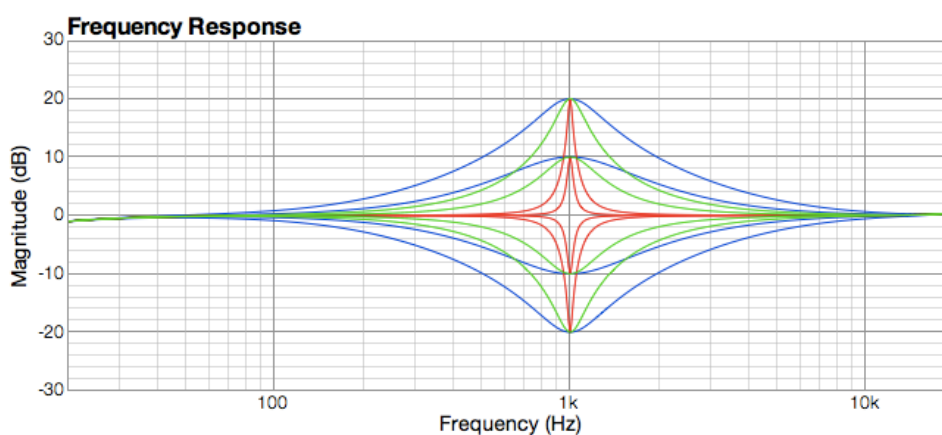

Figure 19: EQ peak and notch filters

The peaking filter with various settings for the Q parameter (width) and the boost/cut parameter is displayed above. The frequency of the filter is set to 1kHz in this example.

In the graphic below you see a low shelf filter and a high shelf filter with various settings for the boost/cut parameter.

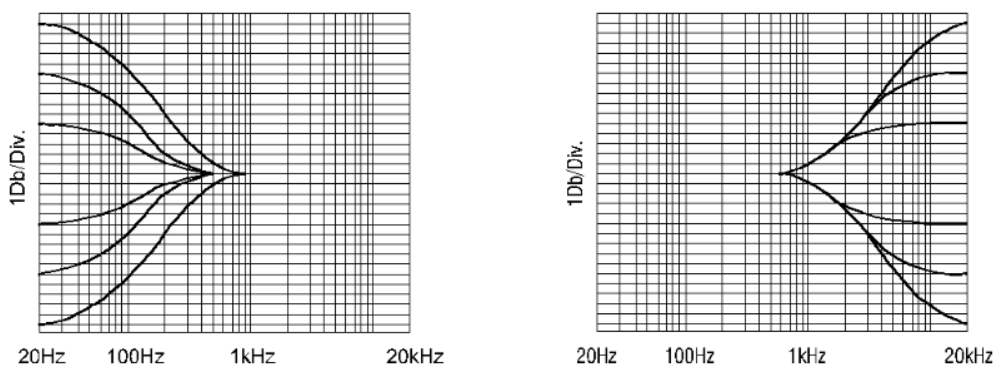

Figure 20: Low shelf and high shelf filter

As a last filter example the high cut filter (also called low pass filter) and low cut filter (also called high pass filter) is displayed.

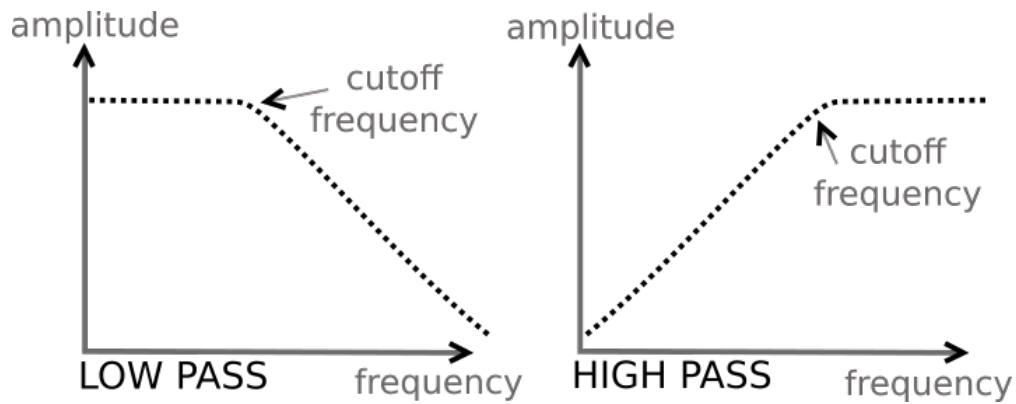

Figure 21: Low pass and high pass filter scheme

To finalize this section you find an example chart that visualizes examples of frequencies for various instrument treatments:

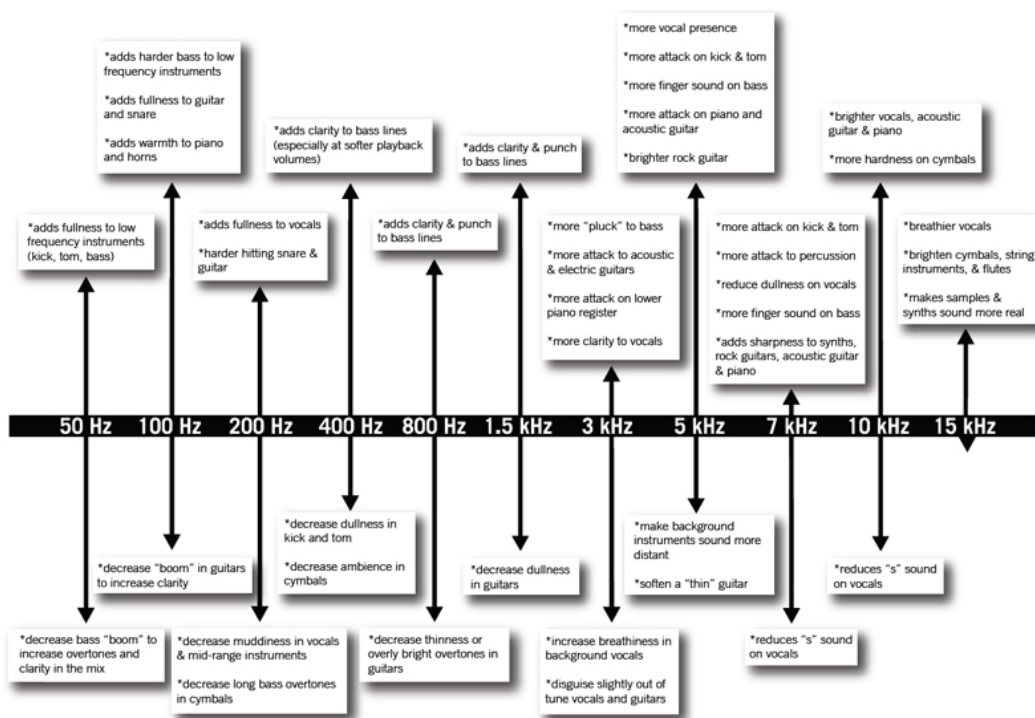

Figure 22: Instruments' spectral treatment overview

4.2 The Weiss Room Equalizer

A room equalizer is used to change the acoustic behaviour of a listening room to some extent. Usually it is best to first take other measures to enhance the characteristics of a room, e.g. by applying absorbers and/or diffusors to the walls, the floor and the ceiling of a room. This plugin is not applicable on headphones.

In a residential environment such a room treatment can be difficult as one may not like to change the looks of a room. This is where a room equalizer comes in handy. The goal is to tame the so called room modes, which are discrete low frequencies where the room resonates.

The frequencies where modes appear depend on the geometric shape of the room.

The *amroc* room mode calculator tool by amcoustics allows you to enter the dimensions of a room and calculates the potential frequencies of room modes:

- amcoustics.com/tools/amroc

The number of different room mode frequencies can be quite large - depending on the room geometry and acoustic properties of the room. In addition the room modes which actually cause problems depend on the positioning of the speakers, the radiation pattern of the speakers and the listening position. Thus the room equalizer based treatment of a room can be quite complex.

One approach is to first find the potential frequencies of the room modes with the help of e.g. the website given above. After that the room modes at those different frequencies can be excited with single frequency tones. If the room resonance can be excited at a frequency that frequency then can be suppressed to some extent with the room EQ.

See section 2.3.6 for instructions about how to find room modes with a slow sine wave sweep.

If a room mode is very pronounced then the room EQ can be set by listening to a music track which is suited to excite that room mode. This would be the simplest method to set the room EQ.

Another approach is to measure the room response with the given speaker positions and listening positions. With those measurements the necessary room EQ settings can be calculated. We are working with the Illusonic company to license their room measuring software for the purpose of calculating the necessary room EQ settings.

4.3 The Weiss Crosstalk Cancellation (XTC)

The so called binaural technology has a long history. Decades ago many live or radio drama recordings have been made using a dummy head microphone as displayed in fig. 23. This head has microphones built into its ears, which allow to record an event in a similar way a listener would hear it.

The idea now is to bring the two recorded channels unchanged to the ears of a listener. The left channel shall go to the left ear only and the right channel to the right ear only. This means there must not be any crosstalk from left to right or right to left.

With such a setup it is possible to reproduce the recorded live event with incredible realism. A headphone allows to transmit the signals to the ears without any crosstalk.

Only, the headphone based playback got other problems, causing such a playback of a dummy head recording often to be unsatisfying.

If it would be possible to play back the recording via speakers then the headphone related problems would be gone.



Figure 23: Dummy head microphone

With speakers there are strong crosstalk components present though. Exactly this a Crosstalk Cancellation (XTC) algorithm tries to suppress.

With a clever signal processing this can be achieved on an impressive level - the acoustics of the recording venue is reproduced in a 3D manner and the musical instruments can be clearly located on a 3D stage. But even studio recordings can be enhanced with an XTC based playback system.

In the figure on the right an XTC listening setup is displayed as a scheme.

The red arrows in the picture indicate the wanted audio signals, while the blue arrows indicate the crosstalk signals which are suppressed.

It is essential to sit in the middle between the speakers such that the setup is completely symmetrical as indicated in the figure.

The listening angle should not be 60 degrees as with a standard stereo setup, but should be more like 20 degree or less.

This helps the XTC impression a lot.

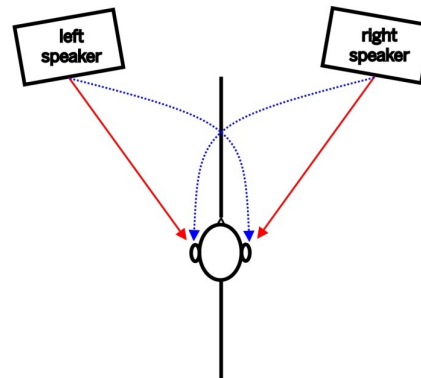

Figure 24: XTC scheme

With the DAC501/DAC502 units it is possible to enter the geometries of the setup. The XTC algorithm then is adjusted to the setup at hand. This plugin is not applicable on headphones.

The main impressions you will get with the XTC based playback are:

- Large stereo stage, much wider than the space between the speakers
- A feeling of depth, i.e. a 3-D like presentation
- Very realistic playback of the acoustic space at the recording venue
- The instruments are clearly located on the stage

The XTC based playback is suited for:

- Dummy head recordings (with the most realistic presentation)
- Live recordings (with an impressive rendering of the acoustic space and the crowd at the place)
- Standard stereo studio recordings
- A mono recording will stay a mono recording. There won't be any "stereo-ization".

4.4 The Weiss Vinyl Emulator

The playback quality of vinyl records often times is viewed as being superior to digital based playback. The technical quality of a vinyl reproduction usually is inferior to a decent digital playback, though.

Obviously many listeners like the specific deteriorations the vinyl playback chain applies to the music.

The playback system in a record player is a fairly complex mechanical system with many variables contributing to the sound. If one likes to emulate such a system in the digital domain the most important mechanisms have to be analysed and emulated.

Some of the sub-systems and parameters involved are:

- motor driving the platter
- needle geometry
- groove geometry

- playback speed
- position of the tonearm
- masses, rigidity of the various mechanical parts (pick-up, tonearm, bearings, ...)
- mechanical to electrical transfer function of the pick-up
- angles of the needle relative to the record
- contact pressure of the needle
- skating effect

One approach to emulate the sonic footprint of a record player would be to simulate all those mechanical/electrical parts one by one for a complete transfer function.

While this is possible to some extent it is fairly complex to implement and also to measure the parts such that their influences are gained isolated from all other effects.

It is simpler and more effective to synthesize the various effects caused by those sub-systems.

These effects are, mainly:

- specific frequency response
- specific distortion patterns
- specific additional resonance frequencies
- specific noise at various frequencies
- specific crosstalk between left and right channels
- specific effects caused by the RIAA emphasis
- specific amplitude modulation effects

The key to a good emulation is to achieve the "right" amounts and characteristics and sequence of all those effects. Hence the word "specific". In the DAC501/DAC502 we implemented a processing chain for the vinyl emulation like this:

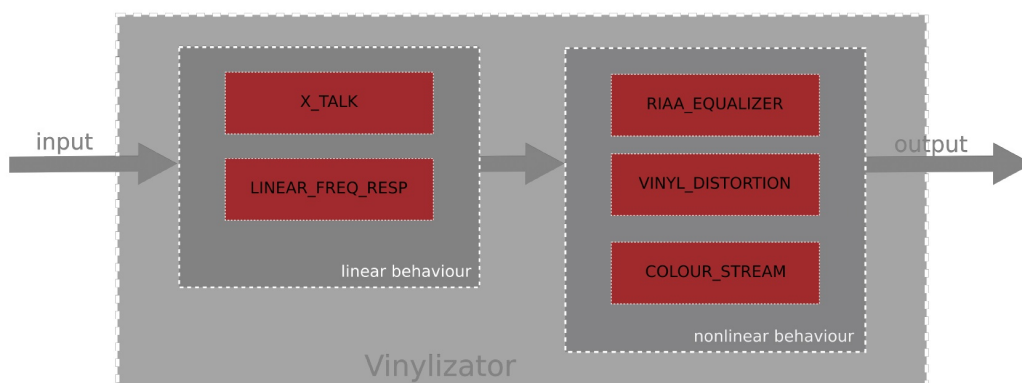

Figure 25: Block diagramm of the Weiss Vinyl Emulator

The blocks are self - explanatory, except *COLOUR_STREAM*, which consists of noise generators, resonance generators and amplitude modulator.

Of course there are many parameters involved in all those processing blocks. For the DAC501/DAC502 our goal was to have a single parameter to control the amount of "vinylization".

That single parameter influences several of the processing block parameters at once. It leads to a very effective and useful implementation with an astonishingly good sounding vinyl footprint.

4.5 Digital level control and Dithering

Digital Level Control – done the right way. With sound examples.

In high-end HiFi circles a level control done in the digital domain is often viewed as being inferior to one operating in the analog domain. Let's look on how a digital level control works and why it can be an excellent solution if it is properly implemented.

A level control is a multiplication of the audio signal with a constant, the "gain factor". The gain factor usually is in the range of zero (signal fully off) to one (signal untouched).

A factor of 0.5 then means that the audio signal is attenuated to half of its amplitude. What exactly happens when we multiply two numbers?

If we e.g. multiply a 2 digit and a 3 digit number, the resulting number can be up to 5 digits long (the sum 2 plus 3). As an example: 30 times 500 equals 15000. 2 digits times 3 digits yields a 5 digit result.

In digital audio, the numbers are represented in the binary system, not the decimal system. A decimal number consists of digits 0 through 9, a binary number of digits 0 and 1.

So a binary number may look like this:

```
1011 0011 0101 1101
```

This is a 16 digit or 16 bit binary number, the grouping into 4 bit chunks is for better readability. The audio samples on a CD are represented with such a binary number system with each sample value represented with 16 bits.

Now let's assume we have an 8 bit gain factor for a level control. If we apply that to a signal coming from a CD we multiply an 8 bit gain factor with a 16 bit sample value. The result is up to 24 bits long (the sum of the word-lengths of the two factors).

An example:

```
0100 1001 x 1001 0110 0111 1011 = 0010 1010 1110 1001 0001 0011
```

The question now is what do we do with the 24 bit long result? The digital to analog converter which converts the samples after the level control may only be capable to handle 16 bit wide samples. Thus what should we do with the excessive 8 bits? The simplest solution is to truncate the 24 sample to 16 bits, i.e. to cut off the 8 less significant bits. The truncated 24 bit result above then would look like this:

```
0010 1010 1110 1001
```

i.e. the first 16 bits of the 24 bit result above. The remaining bits

```
0001 0011
```

are discarded. If these bits are discarded, an error is introduced. This error is called a quantization error, because the 24 bit result is re-quantized to 16 bits.

Unfortunately the quantization error is part of the audio signal – and if we take that part away from the signal, the signal undergoes some distortion, the so called quantization distortion.

The sound example at the link below shows how such a distortion sounds. In this music example a 16 bit signal is truncated to 8 bits. 8 bits in order to clearly show the effect. Notice how the noise (distortion) is modulated by the music signal.

- <https://www.weiss.ch/linked/digital-level-control/nodither.mp3>

This is how a badly implemented digital level control works....

Fortunately there is a better way to handle the re-quantizing. One solution would be to use a D/A converter with a higher word-length, e.g. a 24 bit converter, to accommodate for the 24 bit samples coming out of the level control. This of course would already help a lot, but there is another technique: dithering.

The idea about dithering is to de-correlate the quantization error from the audio signal. As we have seen in the example above, the quantization error depends on the audio signal, i.e. it is correlated with the audio signal. On the other hand, if dither noise is added to the 24 bit sample after the level control and before the re-quantization to 16 bits, the quantization error can be fully de-correlated from the signal. This means

instead of distortion there is noise. The music is undistorted. The audio example at the link below is again a 16 bit signal quantized to 8 bits, but with dither noise added. A much more pleasant experience. Notice how the noise stays untouched by the music, i.e. there is no noise modulation.

- <https://www.weiss.ch/linked/digital-level-control/flatdither.mp3>

Dithering does not stop there. More elaborate dithering schemes shape the noise such that it is mainly present at higher frequencies where the human ear is less sensitive. This means that the audible noise is much lower. The link below is again the 16 bit source quantized to 8 bits with noise-shaped dithering. Probably hard to believe that this is only an 8 bit system! Note that the music is not distorted at all, despite the 8 bit resolution.

Remember, a 16 bit system has 65,536 quantization steps while a 8 bit system has only 256 quantization steps – a huge difference. And still, the properly dithered 8 bit system sounds great.

- <https://www.weiss.ch/linked/digital-level-control/shapeddither.mp3>

This is what a properly dithered level control is capable to do. You have heard the 8 bit version, imagine that with today's 24 bit converters – no question that a level control with a 24 bit word-length easily rivals the best analog level controls. By the way, 24 bits means 16,777,216 quantization steps.

The last example below toggles the noiseshaping dither on and off to give a good contrast between dither/no dither versions.

- <https://www.weiss.ch/linked/digital-level-control/togglingdither.mp3>

Dithering is used in many disciplines. Fig. 26 demonstrates dithering applied to quantized picture data.



Figure 26: Image processing: original (left), quantized without dithering (middle), quantized with dithering (right)

4.6 The Weiss Dynamics Adaption

Nowadays we often have to face the issue that every piece of music can have it's own loudness impression - or it could be preferable to have less dynamics in the playback of a desired play list.

To make you able to control the dynamics of your music in such kind of circumstances we developed the Dynamics Adaption plugin to overcome these problems. Shortly the aim of this algorithm is to avoid big loudness changes or with other words make the user be able to reduce the dynamic range of the played audio. Of course how invasive this controlling should be depends on the taste of the user - so we let you decide by choosing the Dynamic Level.

In the following the algorithm, the parameter Dynamic Level and the recommended use of the Dynamics Adaptions will be explained.

Outline of the algorithm

In the figure below the main functionality of the Weiss Loudness Normalization is outlined. The algorithm is displayed as a simplified block diagram. It consists of four main processing blocks.

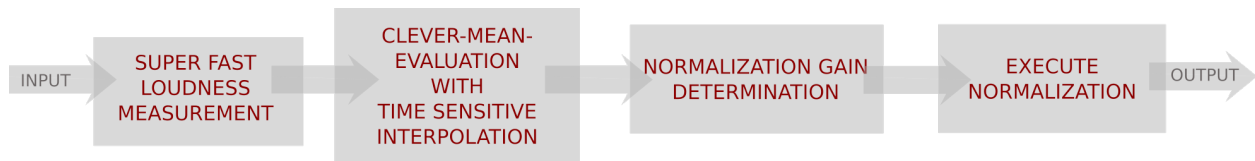

Figure 27: Block diagram of the Weiss Loudness Normalization

The first block Loudness Measurement uses a special procedure to evaluate the loudness envelope of the signal within a very short time period. The characteristics of the human hearing-system are of course included in this loudness measurement regarding the Recommendation BS1770 by the International Telecommunication Union.

With several signal processing tools this measurement will be adapted to become qualified for the use of the normalization. In this way it is possible to create a very fast normalization but also save the important dynamic content of the audio information to make the manipulation not disturbing.

The second block Clever-Mean-Evaluation with Time Sensitive Interpolation is the biggest part of the algorithm. This block contains most of the sundry preparing steps to make the measured loudness envelope suited to be used in the third block. Here the Normalization Gain is determined. Of course a special kind of noise gating is used in this block. And finally the last block performs the adaptation of the audio signal to create an output with constant loudness.

Level Definitions

By adjusting the Dynamic Level you can justify how intense the normalization should effect the audio signal. To be able to use the plugin properly it is helpful to understand how the levels of the plugin effect the audio signal. There are two main levels: the Dynamic Level and the Normalization Level. In the graphic on the right the Normalization Level and the Dynamic Level are displayed.

The Normalization Level is fixed and is used to ensure a proper overall maximum output level.

If you change the Dynamic Level you change the dynamic content of the audio. So if you like to have more dynamics left in your playback use a positive Dynamic Level. The higher this level is the more dynamic content is left in the output. The lower (negative) this level is the less dynamics are left. More and more quite parts of the original audio are amplified. More and more loudness peaks are normalized.

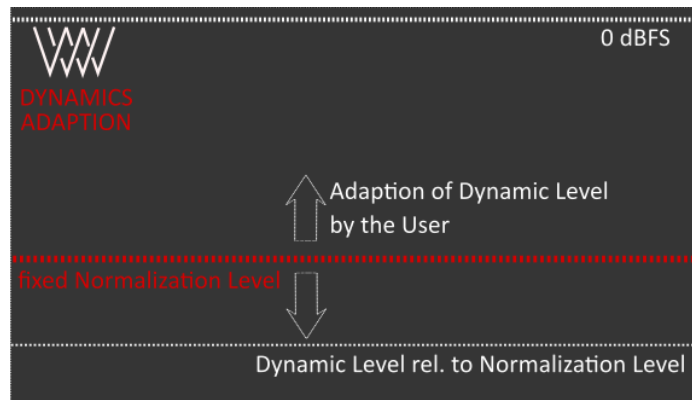

Figure 28: Visualization of relation between dynamic level and normalization level

All in all the whole playback becomes naturally louder when the Dynamic level is very low. Besides it is important to emphasize that the effect of the Dynamics Adaption is depending on the musical content of the actual playback. Some kinds of music have a very wide range of dynamics like a recording of an orchestra. Other pieces are already very compressed concerning their dynamic range.

So it is clear that the effect of the Dynamics Adaption will sound different for different kinds of music. Also the velocity of the loudness changes has an effect on the dynamic. And additionally the spectral content of the music also effects how the output will sound in the end.

This illustrates the big challenge of a good sounding and fully automatic control of the dynamic range.

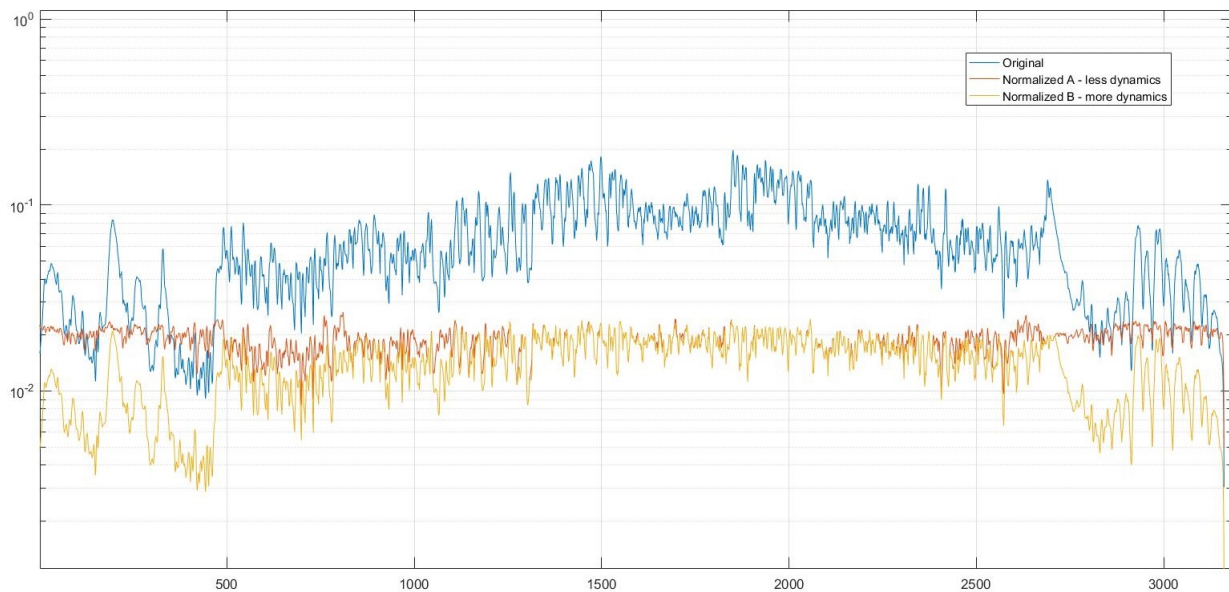

Figure 29: Comparing different settings of the Dynamic Level, (Pink Floyd, Wish You Were Here, live)

As last part of this section we want to show you a nice picture to support the understanding of the functionality of the Dynamics Adaption.

In the figure above you can see three different loudness measurements, displaying the piece of music "Wish You Were Here" by Pink Floyd live. The blue curve shows the loudness of the original audio signal. The curves in yellow and red are normalized ones. The yellow one still contains a lot of the dynamic content of the original. In contrast the dynamic content of the red curve is very limited and the loudness is nearly constant.

The maximum loudness level for both normalized curves is the same. In this figure you can see especially at the beginning and at the end the difference of the dynamic content of the two normalized signals. Besides you can see that the dynamic content of the output of the Dynamics Adaption is level depending. When adjusting the Dynamic Level you should keep this level dependencies concerning your play list in mind.

So for example if you want to avoid annoying loudness peaks in your playback but still desire to keep most of the dynamics choose a Dynamic Level in the range between 0dB and higher. If you have a lot of different recordings with a wide range of loudness levels choose a lower and if needed negative Dynamic Level. The lower this level is the more the dynamic content is limited. The value 0dB is our default setting and should be like the golden middle between the different sound capability of the plugin. We recommend you to start with this default setting. Be careful with very low Dynamic Level settings for some recordings the adaption can sound unnatural.

4.7 The Weiss De-Esser

The sound of sharpness is a natural part of singing vocals - especially when singing S or T consonants. In fact it is a necessary characteristic of such consonants and helps the human ear to identify them. Beyond vocals a lot musical instruments contain sharpness within their characteristic sound. For example the Hi-Hats of a drum set would be hard to recognize without any sound of sharpness.

The science of psychoacoustics describes sharpness as a special timbre. Sounds with sharpness can be distinguished by taking a look at their frequency characteristics. The main part of the signal energy is in the high frequency range. Nevertheless it can happen, that certain high frequencies are too dominant and the sharpness of the sound becomes very displeasing or even harmful for human ears.

This can occur under diverse circumstances. For example inapt conditions of a playback room can emphasize sounds with high sharpness. But also during recording or mastering a boost of sharpness can be added to the music.

To give you the possibility to reduce such displeasing sounds of too high sharpness we developed the automatic Weiss De-Esser. Moreover you are able to choose between two different De-Esser modes and how much of the overall sharpness should be kept. So with the Weiss De-Esser you are able to create your individual desired sound regarding the sharpness of the playback.

The characteristic of sharpness of a S also explains the origin of the name De-Esser - whose purpose is limiting S sounds or in general limiting sounds with sharpness. Below you can see a block diagram of the algorithm of the Weiss De-Esser. There are four main parts of the algorithm which will be introduced in the following.



Figure 30: Block diagramm of the Weiss De-Esser plugin

Sounds with high sharpness are concentrated in the mid-signal of the audio information. So the Weiss De-Esser only processes the mid-signal and lets the side-signal untouched.

This idea is based on the so called m/s-stereophony. Which is a coding process that transforms the signals of the left and right into a different representation. The mid-signal is the sum of the left and right channel. As opposed to this is the side-signal the difference of them. For realizing this idea a m/s-encoding and decoding is integrated at the beginning and the ending of the De-Esser chain.

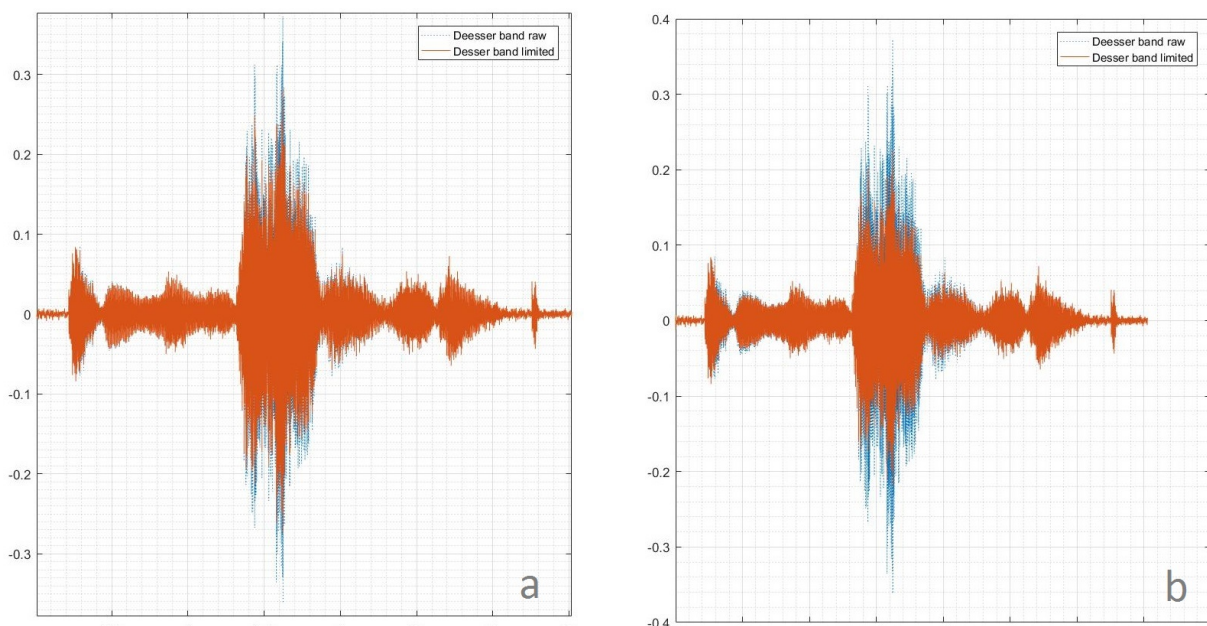

Figure 31: Comparing different settings of the De-Esser user parameter: a) original; b) Amount -12 dB.

The second block performs a sound distinctive analysis. This block enables the De-Esser to recognize certain transformations of the signals frequency content which are important for limiting high sharpness. The measurements of this analysis are super fast like in the section of the Weiss dynamics adoption described. But still the overall picture is captured to factor the slow changing behaviour of the audio into the evaluation. This is warranted by implementing a capacity of remembering into this block.

The knowledge generated by the second block is then used in the third block. Here the decision whether

to activate the De-Esser or not is made. This decision is based on the evaluation of the current frequency content - the sharpness detection - the result indicates how high the sharpness of the audio is. If the sharpness exceeds certain limits the De-Esser is activated.

For the execution of the De-Esser a proper De-Esser gain is needed. The shape of this gain is calculated in order to match the critical high frequencies of the current signal. This takes place in the fourth block. Here the certain gain is applied to the De-Esser band. This De-Esser band is the part of the mid-signal which contains the frequency range that causes the critical sharpness.

Finally the decoding of the m/s-signal can be performed and the deessed output stream can be received. So the presented algorithm of the automatic Weiss De-Esser analyses the incoming information very fast to realize short delays and concurrently uses its ability to take decisions with care based on its knowledge generation about the long-term behaviour of the audio stream.

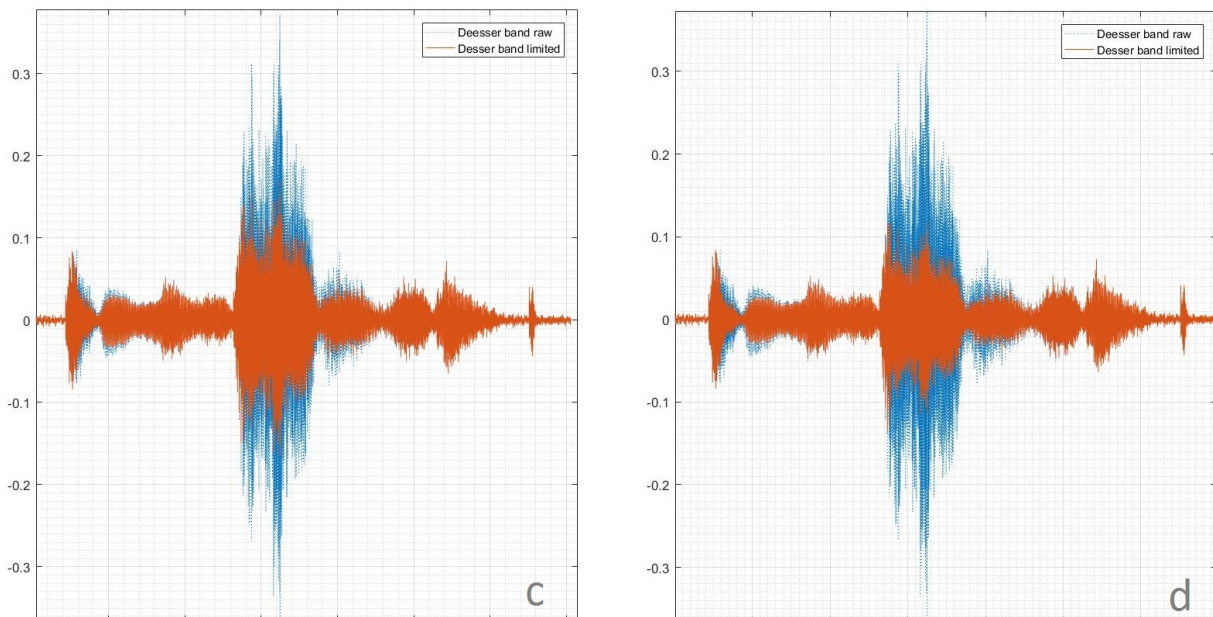

Figure 32: Comparing different settings of the De-Esser user parameter: c) Amount 0 dB; b) Amount 9 dB.

As mentioned above you have the possibility to create your own desired sound of the Weiss De-Esser. The plugin provides two different De-Esser modes - *Surgical* and *Smooth*. Besides you can define the *Amount* of the chosen De-Essing effect.

Independently a special normalization is performed to create a result that is individually matched with the current sound of the music. This is needed on the one hand for the automatic detection of sharpness and ensures the ability of the algorithm to adapt its behaviour to the current musical content. On the other hand it is needed to define the maximal setting of the De-Esser gain which is computed in relation to the actual audio stream. So with the choice of the *Amount* you can choose how strong the influence of the De-Esser should be. But the determination of the maximal possible influence is performed autonomously by the De-Esser to prevent *over deessing* which would sound dull or like lisping.

Different settings of this parameter are visualized in the second and third picture of this section. Here you see how the influence of the user parameter *Amount* is increased. Starting at picture (a), which shows a setting with low influence, till (d), which shows the maximal setting of the influence for this particular example. Besides these pictures show the signal of the De-Esser band. This band only contains the part of the music that could include sharpness. The example of the pictures is the S of the word *myself* of the song "Rainy Days and Mondays" by Susan Wong.

In addition to the parameter *Amount* you can choose between the two modes - *Surgical* and *Smooth*. The *Surgical* mode has a very precise behaviour with focus on the current changes of the high frequency con-

tent. Moreover the effect of the *Surgical* mode compared to the *Smooth* mode is very narrow to match the range of the critical sharpness. In contrary the mode *Smooth* is more soft and observantly about the overall context and long-term behaviour of the music.

We chose these two modes to provide you with a De-Esser plugin for several desired benefits. For example, if you want to get rid of certain critical sharp sounds, the mode *Surgical* is preferential. Because the focus of the mode *Surgical* is on fast changing events and it processes merciless when sharpness is detected.

If you want a more general diminution of the high frequency content the mode *Smooth* is the proper choice. For example if you are listening with headphones the mode *Smooth* can enhance your listening experience. But it is also well suited when listening with loudspeakers, if you like to have a more mellow sound of the high frequency content. The interaction of the mode *Smooth* with the music could be described as more merciful than the *Surgical* mode, but less strict when sharpness is detected.

For defining your favourite De-Esser settings it is important to keep in mind that the De-Esser will respond different to different types of music. So maybe you find a setting of the De-Esser matching your favourite Rock music album. It can happen that you will prefer a different setting for your favourite piano recordings. This is a natural consequence of how the De-Esser works. It processes based on the dynamics of the music and these of course sound different for different kinds of music.

So we encourage you to first play with the Weiss De-Esser to get a feeling of how the different modes sound. For the parameter *Amount* a good starting point could be around -6dB. Furthermore in the beginning it is more easy for getting to know the sound of the De-Esser and finding your own desired setting, if only the De-Esser plugin is enabled.

4.8 The Weiss Crossfeed Headphone Algorithm

The Weiss Crossfeed Headphone Algorithm optimizes the music for the reproduction via headphones. It is especially useful for recordings with extreme channel separation. The figure on the right continues the concepts of the discussion in section 4.3. In contrast to the scenario in 4.3 the usage of headphones realizes a clean separation of the stereo channels regarding the left and right ear.

This is visualized in the figure titled with "Standard Setting". To optimize audio for the reproduction via headphones this separation needs to be reduced. The "Crossfeed Setting" illustrates the main idea of the presented plugin. A certain part of the left channel is blended into the signal directed to the right ear and a certain part of the right channel is added to the left one.

This additional part can be called Crossfeed path and is drawn with a dashed line. So for each ear a summation describes the basic idea of the algorithm:

$$\begin{aligned} \text{left} &= \text{direct}_{\text{left}} + \text{crossfeed}_{\text{right}} \\ \text{right} &= \text{direct}_{\text{right}} + \text{crossfeed}_{\text{left}} \end{aligned}$$

The signals of the Crossfeed paths are processed frequency dependent. It needs to be made clear that the sound of this effect is conditional to the currently played back audio.

The presented plugin also is equipped with a user parameter called *Amount*. With a range of 100 settings of the Crossfeed Headphone effect the user can define its desired sound adjustment. The higher the parameter is defined the stronger is the impact of the plugin.

This plugin is not applicable with *Output Termination* set to *Speaker* (2.3.2).

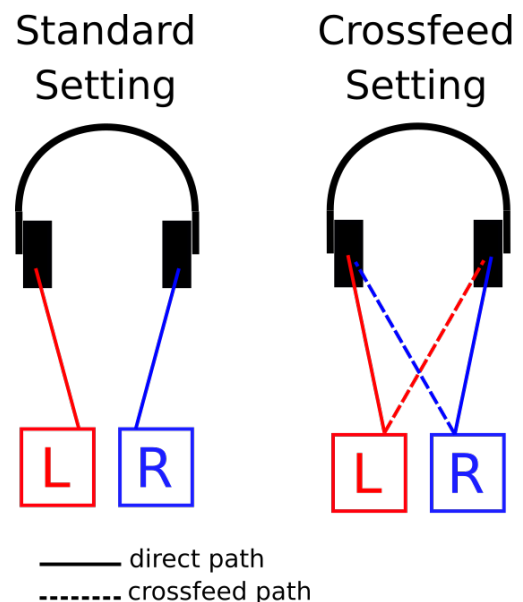

Figure 33: Crossfeed HP scheme

4.9 The Weiss Headphone Equalizer

The Weiss Headphone EQ also pursues the aim of a *spectral compensation* like the Schwede Loudness EQ and the Room EQ. The introduced EQ plugin of this section attempts to balance the playback when using headphones. The specific geometries and constructions of headphones can alter the reproduction of sound. This can create loudness variations regarding certain frequencies in such a way that some frequency bands could be emphasized and others could be dampened.

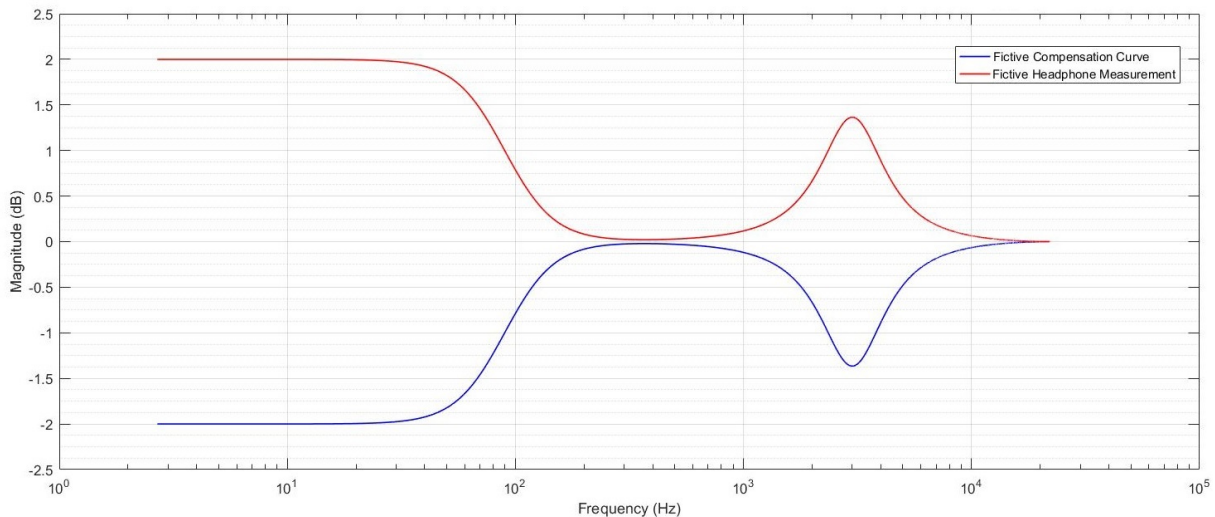

Figure 34: Fictive example of a headphone frequency response measurement (red) and its correlated compensation curve (blue).

Such an imbalance can be compensated if the frequency response of the headphone is known. Measurements of a headphone's frequency response provide information about the spectral amplifying behaviour of the system.

Based on this knowledge it is possible to design filters which are able to compensate this unauthentic behaviour and counterbalance the listening experience of headphones.

In figure 34 a fictive and simplified example of such a headphone frequency response measurement is plotted in red. In reality such measurements are far more complex. This exemplary headphone only creates an amplification imbalance in two frequency bands. The first one shows a damping behaviour of the low frequencies up to around 100Hz . Another peak-like damping behaviour can be observed around 3kHz .

In order to compensate this imbalance the *spectral behaviour* of the headphone needs to be inverted. So the basic idea of a compensation filter designs is to invert or, in other words, mirror the measured curve on the 0dB axis. The resulting compensation curve is plotted in blue in figure 34.

The Weiss Headphone EQ plugin (sec. 2.3.7) offers a selection of predefined EQ settings to compensate the properties of certain headphone models. The design of these EQ settings attempt to optimize the number of active bands, so with a change in complexity of the headphone's frequency response the number of EQ bands vary.

In a first version of this plugin 19 Headphone Models by Audeze are presented as option settings. The underlying headphone measurements of these EQ settings have been conducted and evaluated specifically by Audeze.

This plugin is not applicable with *Output Termination* set to *Speaker* (2.3.2).

4.10 The Schwede Loudness EQ

This plugin is based on the patent: "Equalizer, audio system with such an equalizer and method for equalizing a sound mix" by Bernhard Schwede¹ His design describes an audio equalizer with a special concept. In general Schwede's algorithm aims the purpose of an aurally linearized equalization of a sound mix.

The idea is based on the psychoacoustic characteristics of the human hearing and its anatomy. Our auditory sensitivity is frequency dependent, which also effects the perception of loudness. This sensitivity regarding the loudness can cause an unauthentic sound experience when listening at home to audio recordings for example of a concert hall. So Schwede's concept tries to overcome these non linearities of the human sense of hearing with a equalizer design which creates an optimized compensation curve based on the psychoacoustic and anatomical theory.¹

Basically this equalization consists of seven bands with predefined parameters deduced from Schwede's design¹. Ten different setting options of the EQ plugin are presented. The users select the EQ setting option depending on the current listening level they enjoy the most with their audio equipment.

These ten options are described with *dB* levels. Some example comparisons shall illustrate the *dB* levels. Setting *60dB* could be compared with the loudness of a *verbal communication*, *70dB* for example with a *vacuum cleaner*. *80dB* can be visualized with *street traffic*, *90dB* with a *heavy truck* and *100dB* with a *sawmill*.

4.11 The Weiss M/S Control

→ to be announced

5 Contact Information

Weiss Engineering Ltd.
Daniel Weiss
www.weiss.ch
weiss@weiss.ch

List of Figures

1	The DAC502	1
2	The DAC501	1
3	IR remote control	3
4	Web interface overview	4
5	De-Esser plugin	5
6	Vinyl plugin	6
7	Equalizer plugin	7
8	Room EQ plugin	8
9	Headphone EQ plugin	12
10	Loudness EQ plugin	13
11	Dynamics Adaption plugin	13
12	XTC plugin	14
13	Crossfeed HP plugin	15
14	Snapshots maintenance	16
15	Saving a new snapshot	17
16	Global Preset composer matrix	17
17	Firmware update	18
18	Engineering drawings of the DAC501, DAC502 and the IR remote control	19
19	EQ peak and notch filters	24
20	Low shelf and high shelf filter	24
21	Low pass and high pass filter scheme	25
22	Instruments' spectral treatment overview	25
23	Dummy head microphone	26
24	XTC scheme	27
25	Block diagramm of the Weiss Vinyl Emulator	28
26	Image processing: original (left), quantized without dithering (middle), quantized with dithering (right)	30
27	Block diagram of the Weiss Loudness Normalization	31
28	Visualization of relation between dynamic level and normalization level	31
29	Comparing different settings of the Dynamic Level, (Pink Floyd, Wish You Were Here, live)	32
30	Block diagramm of the Weiss De-Esser plugin	33
31	Comparing different settings of the De-Esser user parameter: a) original; b) Amount -12 dB.	33
32	Comparing different settings of the De-Esser user parameter: c) Amount 0 dB; b) Amount 9 dB.	34
33	Crossfeed HP scheme	35
34	Fictive example of a headphone frequency response measurement (red) and its correlated compensation curve (blue).	36